



8100 & 9100 Series Repair Kit

1/2" DIAM, C, D, E ORIFICES

A trained professional must perform all valve repairs. For instructions on the procedure for repairing and testing the pressure relief valve, refer to latest revision of the Installation, Operation, and Maintenance Manual for the **8100, 9100 Series or 9100 Series Model 20 (ENG-496000, ENG-502000, and ENG-869000 respectively)**. These manuals will go through the step-by-step process of disassembly, replacing the parts, assembling the valve, and testing it. All of these repair kits will include a new **Nozzle (Item 12)**, **Disk (Item 11)**, **Base Seal (Item 14)**, and the valve **O-rings (Items 4, 5, & 13)**. The 9100 Model 20 and valves in 2" bodies will not have Item 4 in the kit. Valves in 2" bodies will have an additional o-ring that will be used with the nozzle conversion adapter (Not Shown in Valve Cutaway). Model 20 Valves will have a new bonnet seal in addition to the other parts listed (Not Shown in Valve Cutaway). Use the diagram below to identify which o-rings belong where within the valve.

SPECIFICATIONS

ORIFICE SIZE:		1/2" DIAM	C	D	E
ORIFICE DIAMETER:	in(mm)	0.520 (13.2)	0.281 (7.1)	0.394 (10)	0.520 (13.2)
ORIFICE AREA:	in ² (mm ²)	0.212 (136.8)	0.062 (40.0)	0.122 (78.7)	0.212 (136.8)
**MAX. PRESSURE:	psig(kPag)	1650 (11376)	8700 (59984)	7500 (51711)	3000 (20684)
ASME GAS FLOW COEFFICIENT		0.798*		0.818	
ASME LIQUID FLOW COEFFICIENT		0.639*		0.707	

*= Value calculated from ASME Slope or Flow Factor

**= Pressure Range only indicates the range of the orifice size, not the parts within the kit.

ITEM NO	PART NAME	ITEM NO	PART NAME
1	CAP	9	SET SPRING
2	LOCKNUT	10	BODY
3	WASHER	11	DISK
4	O-RING	12	NOZZLE
5	O-RING	13	O-RING
6	CENTER BUSHING	14	BASE SEAL
7	ADJUSTMENT BUSHING	15	INLET BASE
8	ADJUSTMENT SCREW		

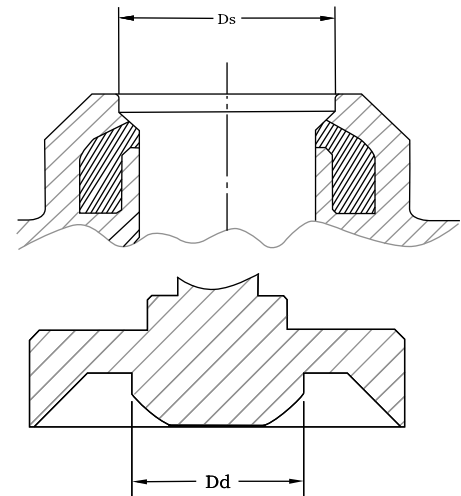
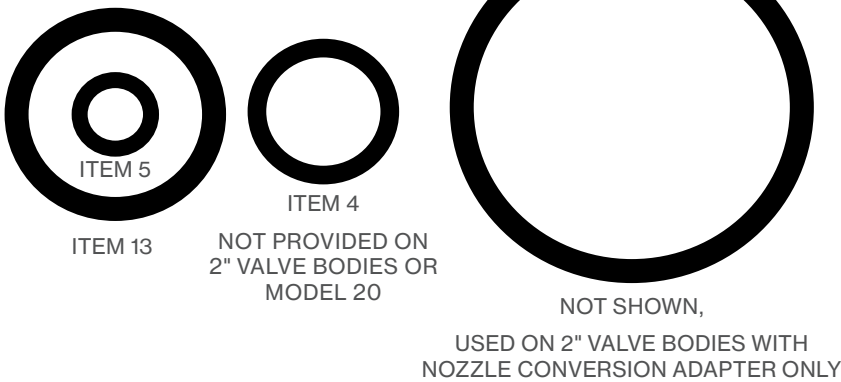
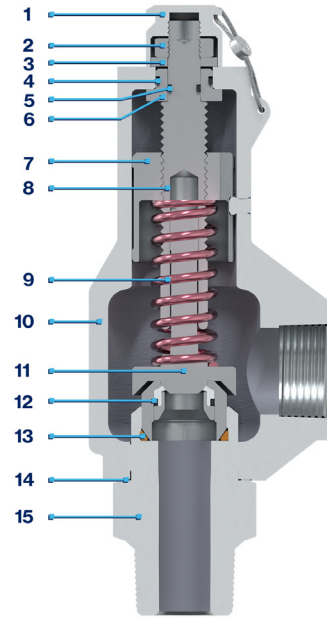

CRITICAL DIMENSIONS

ORIFICE SIZE	NOZZLE DIAMETER D _s , in (mm)		DISK DIAMETER D _d , in (mm)	
	MINIMUM	MAXIMUM	MAXIMUM	MINIMUM
1/2" DIAM	0.620 (15.75)	0.622 (15.80)	0.611 (15.52)	0.614 (15.60)
C	0.335 (8.51)	0.337 (8.56)	0.331 (8.40)	0.333 (8.46)
D	0.480 (12.19)	0.482 (12.24)	0.472 (11.99)	0.475 (12.07)
E	0.620 (15.75)	0.622 (15.80)	0.611 (15.52)	0.614 (15.60)

INSTALLATION — A pressure relief valve should always be installed in a vertical position with its outlet pointing in a horizontal direction on a tank or piping system. When screwing the valve onto the system, always use a square jaw wrench on the designed wrenching flats located at the inlet of the valve, never on the valve's body or bonnet.

One of the most common causes of early failure of a pressure relief valve is seat leakage caused by dirt/debris trapped on the valve seat. Welding slag and piping PTFE tape are among the more common items that cause difficulty. It is recommended that all piping and tank systems be cleaned prior to installation of the valve.

A valve mounted on a tank should be connected with the minimum length of piping between the tank and the valve. Further, all piping used must be equal or larger than the inlet pipe diameter size of the pressure relief valve, **never smaller**. Any restriction of the inlet to a valve may cause unusual valve chatter or relief capacities below the design rating of the valve, which could result in **serious damage**. Similarly, outlet piping from the valve should be less than four (4) feet (1.2 m) in length and never of a pipe size diameter smaller than the outlet size of the valve. Long runs of small diameter pipe on the outlet of a valve will create a serious hazard to life and property. Larger piping is recommended to reduce the built-up back pressure.

Extreme caution is required in the outlet piping if installed outdoors where liquids, if present, could form an ice block in the outlet piping or in the valve's body. In below freezing weather, this will block/restrict flow. Discharge lines must be "weather capped" and provided with a drain hole to prevent any liquid collection in the valve body or outlet piping to prevent this.

Pressure relief valves must be braced and supported for reaction forces, vibrations, and other external forces applied to the valve in operation. Additionally, important installation factors are contained in **Section VIII and Section XIII** of the *ASME Boiler and Pressure Vessel Code*. If any of these precautions are not taken, serious damage and injury may result.

MERCER VALVE CO., INC.

9609 NW 4TH ST, OKLAHOMA CITY, OK 73127

PHONE: (405) 495-6533 • FAX: (405) 495-8728

1- (800) 833-6402

WWW.MERCERVALVE.NET

OPERATION — The valve's set pressure must not exceed the maximum working pressure of the vessel/system. Best performance is usually obtained by installing a valve on a system where the operating pressure is at least **15% less** than the valve's set pressure. **A greater margin is desirable.**

It is also important to check that back pressure and temperature limitations of the process are consistent with valve's ratings. Built-up back pressure should not exceed the allowable overpressure for spring operated valves. Note that each seat and o-ring material has temperature/pressure limitations. Using these materials outside their limitations will cause the valve to fail. Contact Mercer Valve to find different material limitations.

Additionally, corrosion effects from the system's media need to be accounted for in the material selections/compatibilities of the valve's components. Proper material selection and designation is the responsibility of the user/purchaser of the valve. Extra care in material selection must be taken in applications that affect the materials of the valve like Hydrogen service. Standard materials are not acceptable in these types of applications. Contact Mercer Valve Engineering for potential alternative materials.

Carefully check the maximum process fluid input capacities to insure that the valve's relieving capacity is **greater than** the process's capability. It is important that the intended service (gas/liquid) of the valve is installed on a system with same service.

MAINTENANCE & INSPECTION — Mercer Valve recommends all of its pressure relief valves be **tested annually** for set point and function. During these intervals, a visual inspection, set pressure test, and leak check should be done on the valve. All Mercer Valve pressure relief valves are leak checked to at least 90% of set pressure. All inspections and repairs should be done by an authorized and trained professional who has a VR certification.

DO NOT BREAK THE SEAL WIRE. To do so invalidates the manufacturer's warranty to repair or replace the valve. Should resetting be required in a field emergency situation, it should be performed by qualified personnel with calibrated instrumentation. Note that valves should only be reset within the installed spring's set pressure range, which is specified by the manufacturer. Consult factory for additional resetting information.

Consult the Installation, Operation, and Maintenance Manual for additional information.

WARRANTY — MERCER VALVE CO., INC. WARRANTS THE GOODS DELIVERED HEREUNDER TO BE FREE FROM DEFECTS IN MATERIAL AND WORKMANSHIP, UNDER NORMAL USE AND SERVICE, FOR A PERIOD OF ONE (1) YEAR AFTER DATE OF SHIPMENT. MERCER VALVE'S OBLIGATION UNDER THIS WARRANTY IS LIMITED TO REPAIR OR REPLACEMENT, AT MERCER VALVE'S SOLE OPTION, OF ANY DEFECTIVE ITEM. MERCER VALVE'S LIABILITY UNDER THIS WARRANTY IS CONDITIONED UPON PURCHASER GIVING MERCER VALVE IMMEDIATE WRITTEN NOTICE OF ANY SUCH DEFECT. MERCER VALVE SHALL HAVE THE OPTION OF REQUIRING THE RETURN OF THE DEFECTIVE ITEM, TRANSPORTATION PREPAID, TO ESTABLISH THE CLAIM. ANY REPAIR OR REPLACEMENT OF DEFECTIVE GOODS OR PARTS WILL OCCUR AT MERCER VALVE'S PLANT IN OKLAHOMA CITY, OKLAHOMA. PURCHASER SHALL BEAR ALL FREIGHT COSTS INCURRED IN TRANSPORTING DEFECTIVE GOODS OR PARTS TO AND FROM MERCER VALVE'S PLANT. MERCER VALVE SHALL NOT BE HELD LIABLE FOR DAMAGES CAUSED BY DELAYS IN REPAIR OR REPLACEMENT OF ANY DEFECTIVE ITEMS. THE PROVISIONS IN THE MERCER VALVE LITERATURE AND SPECIFICATIONS ARE DESCRIPTIVE ONLY, UNLESS EXPRESSLY STATED AS WARRANTIES. EXCEPT FOR THE FOREGOING, MERCER VALVE EXPRESSLY DISCLAIMS ALL WARRANTIES, EXPRESS AND IMPLIED INCLUDING, WITHOUT LIMITATION, THE IMPLIED WARRANTIES OF MERCHANTABILITY AND FITNESS FOR A PARTICULAR PURPOSE. MERCER VALVE'S LIABILITY TO THE PURCHASER, ARISING OUT OF THE SUPPLYING OF SAID GOODS OR THEIR USE, WHETHER BASED UPON WARRANTY, CONTRACT, OR NEGLIGENCE, SHALL NOT IN ANY CASE EXCEED THE COST OF CORRECTING DEFECTS IN, OR REPLACING, THE EQUIPMENT AS HEREIN PROVIDED. UPON THE EXPIRATION OF SAID ONE (1) YEAR, ALL SUCH LIABILITY SHALL TERMINATE. MERCER VALVE SHALL NOT IN ANY EVENT BE HELD LIABLE FOR ANY SPECIAL, INDIRECT, OR CONSEQUENTIAL DAMAGES. SUITABILITY OF THE MATERIAL AND PRODUCT FOR THE USE CONTEMPLATED BY THE BUYER IS THE SOLE RESPONSIBILITY OF THE BUYER.