



**MERCER VALVE CO., INC.®**  
"AUTO SEAT TECHNOLOGY"®

## **ENG-813000**

**8500 SERIES**

**DIRECT SPRING OPERATED PRESSURE  
RELIEF VALVE**

**INSTALLATION, OPERATION, &  
MAINTENANCE MANUAL**



**MERCER VALVE**

Before installation of a Mercer Valve Co., Inc. Pressure Relief Valve, all sections of this document and all regulatory authority codes must be read and understood. Failure to do so voids all warranties.

REV	ECN	DATE
D	2957	31-May-2018

# Table of Contents

1.	Scope.....	3
2.	Definitions.....	4
3.	Handling and Shipping.....	6
4.	Unpacking and Storing.....	7
5.	Installation.....	8
6.	Operation.....	12
7.	Maintenance.....	13
8.	Inspections .....	15
a)	Visual Inspection .....	15
b)	Set Pressure Inspection .....	17
c)	Leak Inspection.....	18
9.	Test Equipment .....	20
a)	In Situ Testing.....	20
b)	Offsite Testing .....	21
c)	Mobile Test Units .....	22
d)	Test Gauges.....	23
e)	Lift Checking .....	23
10.	Tester Qualifications .....	24
11.	Tool List.....	25
a)	Valve.....	25
b)	Miscellaneous .....	25
12.	Disassembly .....	26
a)	Standard .....	26
b)	Lift Levers.....	28
13.	Component Inspection .....	32
14.	Reassembly .....	34
a)	Cleaning & Lubrication .....	34
b)	Valve Reassembly.....	34
c)	Lift Lever .....	38
15.	Valve Setting Procedure.....	41
a)	Cold Differential Test Pressure (CDTP).....	41
b)	Setting the Valve.....	41
16.	Tag Information .....	42
17.	Product Number System .....	43
a)	Valve Product Numbering .....	43
b)	Repair Kit Product Numbering .....	44
18.	Exploded Views .....	45
19.	Cutaway View.....	46
20.	Trouble Shooting Guide.....	47

**MERCER VALVE COMPANY, INC.**  
**8500 SERIES DIRECT SPRING OPERATED PRESSURE RELIEF VALVE**  
**INSTALLATION, OPERATION AND MAINTENANCE MANUAL**

## **1. Scope**

This document is used for the installation, operation, and maintenance of a Mercer Valve Co., Inc. 8500 Series pressure relief valve. This document should be read and understood before the valve is being maintained, has been installed, or has been put into operation. Failure to do so can result in improper operation that could result in damage to equipment or affect the safety of individuals around the equipment. The recommendations in this document should be used in conjunction with all regulatory bodies and all end-user company's policies.

Proper safety precautions must be followed during all procedures indicated in this document. This document does not cover these precautions or the required safety equipment.

Additional information on installation, operation, and maintenance can be found in the following specifications. These specifications should be used in addition to this document but are not limited by it.

**American Petroleum Institute:**

API 510 – Pressure Vessel Inspection Code

API RP 520 Parts I & II – Sizing, Selection, and Installation of Pressure-Relieving Devices in Refineries

API RP 521 – Guide for Pressure-Relieving and Depressuring Systems

API STD 526 – Flanged Steel Pressure Relief Valves

API STD 527 – Seat Tightness of Pressure Relief Valves

API RP 576 – Inspection of Pressure-Relieving Devices

API STD 598 – Valve Inspection and Testing

**American Society of Mechanical Engineers:**

ASME PTC 25 – Pressure Relief Devices

ASME Boiler and Pressure Vessel Code Section VIII, Division 1 – Unfired Pressure Vessels

ASME B16.5 – Pipe Flanges and Flanged Fittings

**National Board of Boiler Inspectors:**

NB-18 – Pressure Relief Valve Certifications

NB-23 – National Board Inspection Code

MERCER VALVE CO., INC. RESERVES THE RIGHT TO CHANGE  
PRODUCT DESIGNS AND SPECIFICATIONS WITHOUT NOTICE.

Rev.: D

Date: 31-May-2018

ECN: 2957

Page | 3

**MERCER VALVE COMPANY, INC.**  
**8500 SERIES DIRECT SPRING OPERATED PRESSURE RELIEF VALVE**  
**INSTALLATION, OPERATION AND MAINTENANCE MANUAL**

## **2. Definitions**

**Accumulation** is the amount of pressure increase above the MAWP of the system that is allowed. Accumulation is set from the applicable codes.

**Backpressure** is the amount of pressure on the outlet side of the pressure relief valve. This is pressure downstream of the nozzle of the pressure relief valve. It is a combination of superimposed and built-up backpressures.

**Blowdown** is the reclosing point of the pressure relief valve. It can be expressed as a pressure but is most commonly expressed as a percentage of the set pressure.

**Built-up Backpressure** is pressure on the outlet of the pressure relief valve that is caused by the flow of the pressure relief valve. Piping size, length of outlet pipe, fittings, or other flow friction producing items all affect the Built-up Backpressure.

**Capacity** is the flow rate as required by the applicable code.

**Cold Differential Test Pressure (CDTP)** is the pressure the pressure relief valve is adjusted to open on the test stand. The CDTP includes corrections for the service conditions of backpressure or temperature or both.

**Conventional Pressure Relief Valve** is a direct spring operated valve where the spring tension is used to hold the disk closed. The operational characteristics of the valve are directly affected by changes in the backpressure. These characteristics include opening pressure, closing pressure, relieving capacity, and valve function. This is also referred to as a spring operated pressure relief valve (SOPRV).

**Inlet Size** is the nominal pipe size (NPS) of the inlet of the pressure relief valve.

**Leak-test Pressure** is the pressure below the set pressure that the leak test is to be performed. This pressure is often calculated as a percentage of the set pressure.

**Lift** is the amount of travel of the disk from the fully closed to the fully open position when the valve is relieving.

**Maximum Allowable Working Pressure (MAWP)** is the pressure rating the system can withstand at a specific temperature. The MAWP is often used as the setting of the pressure relief valve.

**Outlet Size** is the nominal pipe size (NPS) of the outlet of the pressure relief valve.

MERCER VALVE CO., INC. RESERVES THE RIGHT TO CHANGE  
PRODUCT DESIGNS AND SPECIFICATIONS WITHOUT NOTICE.

**MERCER VALVE COMPANY, INC.**  
**8500 SERIES DIRECT SPRING OPERATED PRESSURE RELIEF VALVE**  
**INSTALLATION, OPERATION AND MAINTENANCE MANUAL**

**Over Pressure** is the amount of pressure increase above the set pressure allowed for the pressure relief valve to achieve full lift and full flow. Set pressure plus Over Pressure should never exceed MAWP plus accumulation but often they will be equal.

**Pressure Relief Valve (PRV)** is a pressure relief device designed to open and relieve excess pressure and to reclose and prevent the further flow of fluid after normal conditions have been restored.

**Set Pressure** is the pressure on the inlet of the pressure relief valve that the valve is set to open. Each pressure relief valve manufacturer will define this setting based on how their valve is to act. Set pressure definitions for each manufacturer's series can be found in NB-18.

**Simmer or Warn** is the audible or visual release of test fluid from between the disk and seat prior to opening of the valve. This is caused by the force holding the disk closed and the inlet pressure force equalizing just before valve begins to open at the set pressure.

**Superimposed Backpressure** is the pressure on the outlet of the pressure relief valve that is caused by a closed discharge system. This type of backpressure is present before the valve begins to open. It can be constant or variable. Superimposed Backpressure can affect the set pressure of a conventional spring operated PRV.

**VR** is an accreditation the National Board offers to organizations/facilities that have shown to independently operate and repair pressure relief valves sufficiently within codes and regulations.

MERCER VALVE CO., INC. RESERVES THE RIGHT TO CHANGE  
PRODUCT DESIGNS AND SPECIFICATIONS WITHOUT NOTICE.

Rev.: D  
Date: 31-May-2018  
ECN: 2957

**MERCER VALVE COMPANY, INC.**  
**8500 SERIES DIRECT SPRING OPERATED PRESSURE RELIEF VALVE**  
**INSTALLATION, OPERATION AND MAINTENANCE MANUAL**

### **3. Handling and Shipping**

Mercer Valve Co., Inc. produces a very durable pressure relief valve. Even though these valves are able to take some abuse, it is recommended that they are handled and shipped with care. This will help prevent damage prior to their installation. These PRVs are safety devices and are the last line of defense before a system over pressures. An impaired PRV could leave the system unprotected.

A PRV should be carried by a structural part such as the body, flange, or eye bolts. If the valve is dropped, it should be checked to assure proper function still exists. Any damage to the connections (flanges, threads, etc.) such as denting and scratching may cause a leak or inhibit proper installation. All precautions to ensure no damage occurs to the valve should be taken.

During shipping, all open ports of the PRV should be sealed to prevent dirt and moisture from entering. Proper precautions to prevent rust should be taken. All flanges and threads should be covered with protectors to prevent damage. The valve should be sealed in a plastic bag.

The valve may be placed in a shipping container upright or on its side however it should be packed so that it cannot move within. Movement can cause the valve to become damaged during the shipping process. The proper shipping container should be chosen for the size and weight of the valve. After being packaged the shipping container should be handled with care.

MERCER VALVE CO., INC. RESERVES THE RIGHT TO CHANGE  
PRODUCT DESIGNS AND SPECIFICATIONS WITHOUT NOTICE.

Rev.: D  
Date: 31-May-2018  
ECN: 2957

**MERCER VALVE COMPANY, INC.**  
**8500 SERIES DIRECT SPRING OPERATED PRESSURE RELIEF VALVE**  
**INSTALLATION, OPERATION AND MAINTENANCE MANUAL**

## **4. Unpacking and Storing**

A PRV should be installed immediately after being removed from the storage/shipping box when it is possible. When the valve cannot immediately be installed, certain storage precautions should be taken to keep it functioning properly until it is. Following these recommendations will encourage proper function of the valve prior to installation. These recommendations only apply to Mercer Valve Co., Inc. manufactured pressure relief valves. Other valve brands can have different requirements and their manufacturer should be contacted for information.

The PRV should be stored in a dry, indoor environment at temperatures between 50°F (10°C) to 90°F (32°C). The inlet and outlet of the valves should be protected from any possible damage. Threaded valves should have thread protectors installed. Flanged connections should be covered to protect their raised faces from scratches and dents. The protectors should also seal the openings so that foreign materials cannot ingress.

PRVs are usually stored vertically to keep parts aligned however this isn't required for Mercer's PRVs. Although vertical storage can help with initial startup in certain circumstances, these valves may be stored horizontally.

Before installing a valve that has been stored, it should be visually inspected for any damage. It is recommended to test the valve before installation if it has been stored for more than one (1) year.

MERCER VALVE CO., INC. RESERVES THE RIGHT TO CHANGE  
PRODUCT DESIGNS AND SPECIFICATIONS WITHOUT NOTICE.

**MERCER VALVE COMPANY, INC.**  
**8500 SERIES DIRECT SPRING OPERATED PRESSURE RELIEF VALVE**  
**INSTALLATION, OPERATION AND MAINTENANCE MANUAL**

## **5. Installation**

Proper installation of a PRV is mandatory to ensure safe and accurate operation. Incorrect installation can cause failures that result in damage or destruction to the equipment and also possible injuries or even death to anyone around the equipment.

Before installation, the valve should be visually inspected for any damage that occurred during shipping and storage. If any damage is found, do not install and immediately contact Mercer Valve Co., Inc.

Always remove all thread and flange protectors from the inlet and outlet before installing. These protectors can stop pressure from entering or exiting the PRV and result in malfunction. Make sure that a test gag is not engaged when the valve is in operation. Test gags are only used in controlled over pressures situations such as hydrostatic testing of the system.

The set pressure should be tested after the valve has been shipped great distances or has been in long term storage before installation. This verification helps to confirm valve function and correct settings.

It is also important to check that the backpressure and temperature of the application are within the valve's ratings and limitations. There are two types of backpressure, superimposed and built-up. Each type of backpressure affects the valve differently. Superimposed backpressure can come in two forms, variable and constant. The correct form of backpressure must be considered during the selection and sizing of the valve; if the wrong type is assumed, the valve may not operate properly. Built-up backpressure should not exceed the allowable overpressure for conventional PRVs. The PRV's seat and o-rings have temperature-pressure limitations. Using these materials outside their limitations will cause issues. Contact Mercer Valve to find the limitations of the valve.

Compatibility, in terms of reactivity and corrosion, between the system's media and the materials used within the valve must be considered. Appropriate material selection is the responsibility of the user/purchaser of the valve.

The nameplate information should be verified for the service conditions of the application before the valve is installed. The fluid state, capacity, service temperature, set pressure, and backpressure can all be found on the PRV's nameplate, which is also called the tag. If the information indicates improper settings or the wrong service conditions, the valve should not be installed. The service temperature listed is not the temperature limit. It is important that the set pressure is examined against the system's MAWP.

The PRV should be oriented in a vertical position with its inlet pointing downwards and its outlet pointing in a horizontal direction. Mercer Valve Co., Inc. must be contacted to ensure proper operation if the valve cannot be installed in this orientation.

MERCER VALVE CO., INC. RESERVES THE RIGHT TO CHANGE  
PRODUCT DESIGNS AND SPECIFICATIONS WITHOUT NOTICE.



**MERCER VALVE COMPANY, INC.**  
**8500 SERIES DIRECT SPRING OPERATED PRESSURE RELIEF VALVE**  
**INSTALLATION, OPERATION AND MAINTENANCE MANUAL**

Use a suitable sealing mechanism (PTFE pipe tape, gasket, etc.) when installing a PRV on a system. When screwing a threaded valve onto piping, always use the wrench flats on the inlet connection. See Figure 1. Use a square jaw type of wrench. Do not put a wrench on the PRV's body or bonnet during installation. Tighten 1.5 to 3 turns past finger tight for national pipe threads. Flanged valves require the correct amount, type, and size of bolts and the type of gasket used. Flange information can be found in ASME B16.5.

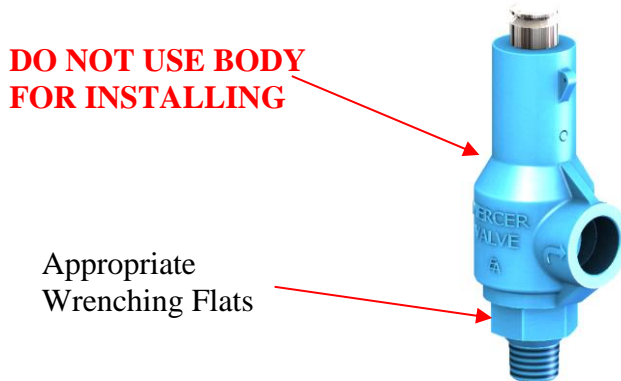

Figure 1: 8500 Series Threaded Valve Wrenching Flats

One common cause of early PRV failure is debris trapped on the valve's seat resulting in a leak. Weld slag and pipe tape are among the more common items that cause this. It is recommended that all piping and tank systems are cleaned prior to the initial installation of the PRV.

A pressure relief valve should be attached to the system with the shortest amount of piping possible. All piping leading to the PRV used must be equal to or larger than the PRV's inlet pipe size; it must **never be smaller**. Any restriction within the inlet lines can cause unusual valve chatter, which results in serious damage to the valve. It is recommended that any pressure drop created from inlet piping is less than 3% of the set pressure. Piping restrictions also can reduce the relief capacity of the valve, which can leave the system unprotected.

Outlet piping should be as short and direct as possible to keep built-up backpressure low. In spring operated PRV, built-up backpressure should never exceed the allowable over pressure. For most but not all cases, the allowable over pressure is 10% of the set pressure. It is recommended that the outlet piping be less than 4 feet (1.2 meters) in total length. Its nominal size should be equal to or greater than the outlet size of the PRV. Increasing the outlet piping size will reduce the built-up backpressure potential and enable longer lengths. Long runs, additional fittings and bends, and small diameter pipes will increase the propensity of valve chatter. Valve chatter can have damaging effects and will reduce the relieving capacity, which potentially leaves the system unprotected.

MERCER VALVE CO., INC. RESERVES THE RIGHT TO CHANGE  
PRODUCT DESIGNS AND SPECIFICATIONS WITHOUT NOTICE.

**MERCER VALVE COMPANY, INC.**  
**8500 SERIES DIRECT SPRING OPERATED PRESSURE RELIEF VALVE**  
**INSTALLATION, OPERATION AND MAINTENANCE MANUAL**

Special consideration should be made when multiple relief valves are installed on a system with a common discharge header. The size of the header should be based on the sum of the discharge areas for each relief valve and any pressure loss. The built-up backpressure still cannot exceed the allowable overpressure. When greater built-up or variable superimposed backpressure exists, an 8500 series valve may not be suitable and Mercer Valve Co. should be consulted prior to installation.

PRVs must be braced and supported for reaction forces, vibrations, weight, and other external forces applied during operation. These and all other loads must be taken into account when installing the valve and adding bracing.

See Figure 2 for an example installation of a pressure relief valve.

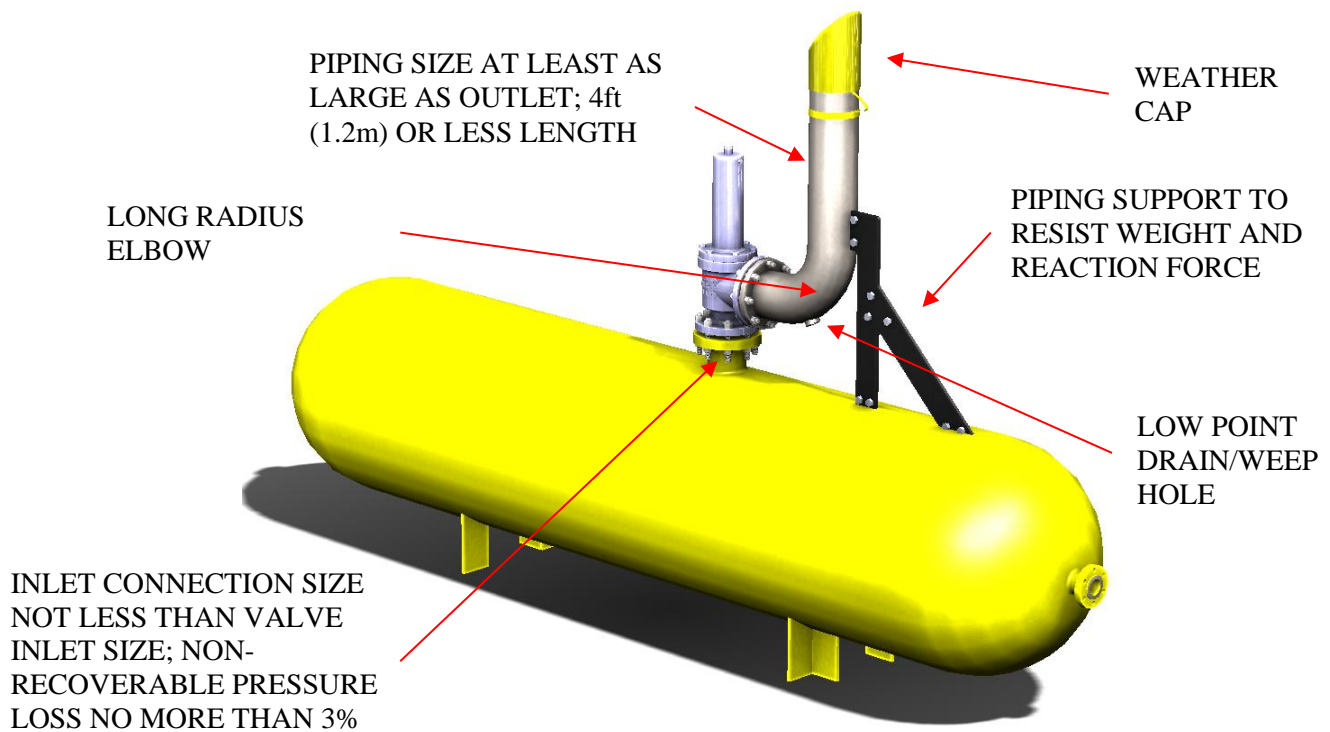

**Figure 2: Typical Recommended Installation of a PRV**

Excessive vibrations can cause a PRV to open below its intended set pressure. Vibrations apply acceleration to the movable parts within and create an upward force. When this force is added to the force balance within the valve, the required pressure to open the valve is lowered. When the operating pressure is close to the set pressure and vibrations exist, premature relieving can occur.

Extreme caution is required regarding the outlet piping if liquid can be present. The presence of liquid can increase the required force the valve needs to open and this alters the actual relief pressure. At low temperature the liquid can freeze and form an ice block in the discharge piping

MERCER VALVE CO., INC. RESERVES THE RIGHT TO CHANGE  
PRODUCT DESIGNS AND SPECIFICATIONS WITHOUT NOTICE.

**MERCER VALVE COMPANY, INC.**  
**8500 SERIES DIRECT SPRING OPERATED PRESSURE RELIEF VALVE**  
**INSTALLATION, OPERATION AND MAINTENANCE MANUAL**

or valve body that restricts the relief flow. Discharge lines should be weather capped and provided with a drain hole to prevent liquid from collection. If these precautions are not taken, the valve may not be able to protect the system.

**DO NOT BREAK THE SEAL WIRE.** Breaking the seal wire invalidates the manufacturer's warranty to repair or replace the valve. If resetting is required in a field emergency situation, qualified personnel with calibrated instrumentation should perform it. A PRV with a broken seal wire is not considered to be an ASME Coded valve until it has been repaired by a VR Certified repair shop.

Important installation information is contained in Paragraph UG-135 and Appendix M of the ASME Boiler and Pressure Vessel Code and in API RP 520 Part 2. Other standards and codes may be applicable depending on the jurisdiction and area of use.

MERCER VALVE CO., INC. RESERVES THE RIGHT TO CHANGE  
PRODUCT DESIGNS AND SPECIFICATIONS WITHOUT NOTICE.

Rev.: D  
Date: 31-May-2018  
ECN: 2957

**MERCER VALVE COMPANY, INC.**  
**8500 SERIES DIRECT SPRING OPERATED PRESSURE RELIEF VALVE**  
**INSTALLATION, OPERATION AND MAINTENANCE MANUAL**

## **6. Operation**

The Mercer Valve 8500 Series is an ASME Section VIII, Division 1 certified PRV for gas/vapor applications. It has a set pressure definition of a “POP.” When the valve reaches set pressure, the disk will open creating a “POP” sound. The valve could exhibit simmer or warn before its set pressure but this is not considered the set point. The valve will open to full lift at set pressure.

The 8500 Series is a direct spring operated PRV. The valve uses spring compression to keep the valve closed. The inlet pressure opens the valve. In normal operation, the spring compression has been adjusted to achieve the set pressure setting of the valve. The spring tension pushes down on the disk that presses against the nozzle subassembly. The disk seals against the seat within the nozzle subassembly. The pressure on the inlet pushes up on the disk through the nozzle. At set pressure, the force generated by the inlet pressure exceeds the spring’s force. This makes the disk rise up letting the inlet pressure escape past the seat. The disk stem is guided by the adjustment screw’s bore, which keeps the disk aligned with the nozzle subassembly during this movement. The disk rises until it reaches a mechanical stop located on the adjustment screw. At this point the valve is at full lift and will flow the media at its discharge coefficient rating. The PRV’s orifice should be sized so its capacity rating, at the allowable overpressure, exceeds the maximum flow capacity the system will produce. Sizing information can be found in ASME Boiler and Pressure Vessel Code (BPVC), Section VIII, Division 1, Appendix 11 and in API RP 520 Part 1. Additional requirements by local authorities also need to be considered. Since the PRV’s flow capacity will exceed the required capacity of the system, the system pressure will drop. The valve will reclose when the inlet pressure has dropped enough to allow the spring force to push the disk back down against the seat. The disk will reset against the seat stopping any further flow and the valve will be ready for the next overpressure event.

Best performance is usually obtained on a system where its operating pressure is at least 15% less than the valve’s set pressure for gas applications. Performance improves with greater margin between the operating and set pressures. A larger margin helps with the reclosing of the PRV and reduces the chance of inadvertent opening from system characteristics such as pressure pulses, vibration, temperature, and etc. ASME’s BPVC and API’s standards require the set pressure does not exceed the MAWP of the system.

MERCER VALVE CO., INC. RESERVES THE RIGHT TO CHANGE  
PRODUCT DESIGNS AND SPECIFICATIONS WITHOUT NOTICE.

Rev.: D  
Date: 31-May-2018  
ECN: 2957

**MERCER VALVE COMPANY, INC.**  
**8500 SERIES DIRECT SPRING OPERATED PRESSURE RELIEF VALVE**  
**INSTALLATION, OPERATION AND MAINTENANCE MANUAL**

## **7. Maintenance**

For dependable performance, PRVs must be maintained regularly. **Mercer Valve Co., Inc. recommends its PRVs are inspected and tested annually.** After the valve has been installed and a service history has been established, the testing and inspection frequency may be adjusted. Some guidelines for testing frequencies are found in NB-23, API 576, and API 598. Additionally, government jurisdiction should be reviewed. When maintenance is done, qualified repair personnel should perform it. Qualified repair personnel conducting the annual inspection and testing may alter the maintenance schedule based on the service conditions.

During the inspection, a visual inspection, a set pressure verification, and a leak check should be completed. These tests can be performed while the PRV is installed on its system or when it's on a testing bench. The PRV can only be tested while on its application if there is a method and procedure to apply a controlled pressure to the PRV's inlet without exceeding any limits of the system.

A visual inspection is used to identify if the PRV is installed properly, is correct for the application, and doesn't have apparent problems. Check the nameplate information to verify that the valve is installed on the proper service. A missing nameplate requires immediate addressing. If the valve is installed on gas/vapor service, the nameplate's capacity will indicate an air capacity at standard conditions. If the valve is on liquid service, the nameplate will indicate a water capacity. Check the seal wire. A broken seal wire indicates that an unqualified person has adjusted the set pressure; this also removes any warranty the valve had. The valve should be inspected for damages. If there is damage to the valve it may not operate properly. Look for potential issues that would keep the valve from opening or would inhibit flow. Rust or dirt accumulation, insect or animal nests, pooled water, and etc. are all things that can restrict the flow or stop the valve from opening. If any problems are found during the visual inspection, the valve must be repaired by a qualified person or replaced with an equal.

When verifying the set pressure, the appropriate fluid should be used. Gas/vapor PRVs should only be tested with a gas, usually air or nitrogen. Liquid PRVs should be tested only with liquid, usually water. Testing a pressure relief valve with the incorrect fluid will cause inaccurate readings. The set pressure of the pressure relief valve, in accordance with the ASME Boiler and Pressure Vessel Code, has a tolerance of  $\pm 3\%$  of the specified set pressure or  $\pm 2\text{psi}$  ( $\pm 15\text{kPa}$ ), whichever is greater. If the examined set pressure is not within this tolerance, the PRV should be reset or possibly repaired by qualified repair personnel. A PRV's set pressure definition will depend upon its manufacturer and will be listed within NB-18 publication if its ASME certified; this can be found at <http://www.nationalboard.org/>.

After the set pressure has been verified, the valve is leak checked. The valve is checked for any leaks coming from its seat. Leak checks are usually performed at 90% of the set pressure or 5psi (34.5kPa) below set pressure, whichever is greater. The valve must be actuated and resealed to

MERCER VALVE CO., INC. RESERVES THE RIGHT TO CHANGE  
PRODUCT DESIGNS AND SPECIFICATIONS WITHOUT NOTICE.

**MERCER VALVE COMPANY, INC.**  
**8500 SERIES DIRECT SPRING OPERATED PRESSURE RELIEF VALVE**  
**INSTALLATION, OPERATION AND MAINTENANCE MANUAL**

perform this test. The pressure is then brought to and held at the leak check pressure. If the valve does not pass a leak check, it will need to be repaired by a qualified person or replaced with an equal.

***Start of Service Period***

In many codes and standards there is ambiguity about when the PRV's inspection interval begins for newly constructed equipment. When a governing code or standard has defined this start date specifically, then it should be followed. When the start date is not specified, the following is what Mercer Valve Co. recommends for its products, which will clarify this ambiguity should the user/owner of the PRV adopt it to their standards. This recommendation is irrespective of the warranty Mercer Valve Co. has for its goods.

Contingent that proper storage and transportation of the PRV was accomplished, the start time for the inspection interval, otherwise known as service life, is the PRV's commissioning date not exceeding one year after it was manufactured; the manufactured date is listed on the PRV's nameplate. Commissioning is defined as the first time the equipment is operated with the PRV installed.

This recommendation is based on Mercer Valve's storage policy. Mercer Valve recommends testing a valve only if it has been in storage for more than a year. Testing of the valve should be in accordance with NB-23 standards with a clean, inert media. The testing must not excessively exercise the valve. The valve should not have any wear or damage prior to the commissioning date.

Additional maintenance instructions can be found in API RP 576, ASME Boiler and Pressure Vessel Code Section VIII, Division 1, and the National Board Inspection Code.

MERCER VALVE CO., INC. RESERVES THE RIGHT TO CHANGE  
PRODUCT DESIGNS AND SPECIFICATIONS WITHOUT NOTICE.

Rev.: D  
Date: 31-May-2018  
ECN: 2957

**MERCER VALVE COMPANY, INC.**  
**8500 SERIES DIRECT SPRING OPERATED PRESSURE RELIEF VALVE**  
**INSTALLATION, OPERATION AND MAINTENANCE MANUAL**

## **8. Inspections**

Pressure relief valves are used to help with safe operation of a system that they are installed on. They are designed to stop excessive over pressure scenarios. More information on causes of over pressure can be found in API 521. If a PRV fails during an over pressure scenario, the system can increase to an unsafe pressure. These over pressure situations can exceed the MAWP and result in failures. These failures can be catastrophic in nature and result in damages to the system or even destruction of the equipment. The safety of people around the system will be affected as well. Because of the gravity of these types of failures, keeping pressure relief valves in proper working order is essential. Regular inspections are conducted to assure a functioning PRV.

These inspections are used to verify if the PRV is suitable for the service conditions it is installed in. If the PRV is not correct for the conditions, it may not be able to protect the system properly and result in failures.

The inspection of the PRV can be done while in place, while in the field, or offsite within a repair shop. During the inspection, three tests should be performed: a visual inspection, a set pressure test, and a leak test. Using these three inspections can help determine the functionality of the valve or if repair or replacement is required.

Relief valves can generate an enormous amount of noise and pose other hazards to personnel during its operation. Appropriate personal protective equipment must be worn and other safety standards must be followed when working with pressure relief valves.

### ***a) Visual Inspection***

During the visual inspection, the pressure relief valve is checked for any potential issues that may restrict the operation of the valve. This inspection will be performed with the valve still assembled but the valve should not be pressurized for the safety of the person performing the inspection. Corrosion and damage to the valve are some of the common problems found in the visual inspection. Some of the items that should be checked in the visual inspection are as follows:

- **Cap and Seal Wire** – The valve cap and seal wire should be checked first on all inspections. These parts prevent adjustment tampering. On the seal wire there is a pressed security seal that has an impression on it to indicate the certified company that last adjusted the set point of the valve. When this seal wire is cut or removed, it indicates that someone may have adjusted the set point or altered the valve. This voids any warranty the valve had. See Figure 3.

MERCER VALVE CO., INC. RESERVES THE RIGHT TO CHANGE  
PRODUCT DESIGNS AND SPECIFICATIONS WITHOUT NOTICE.

**MERCER VALVE COMPANY, INC.**  
**8500 SERIES DIRECT SPRING OPERATED PRESSURE RELIEF VALVE**  
**INSTALLATION, OPERATION AND MAINTENANCE MANUAL**

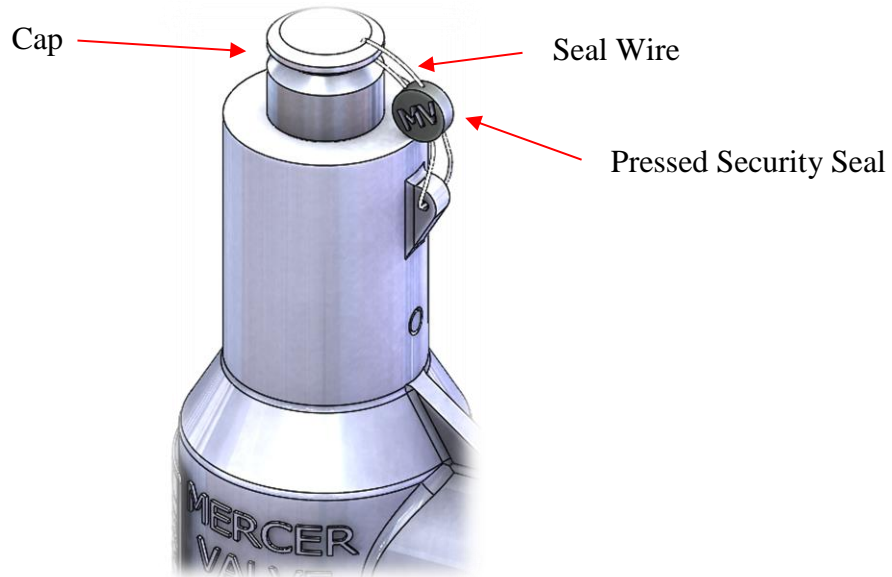

Figure 3: Typical Cap and Seal Wire

- Flanges Connections – The flanges should be checked for wear, such as pitting, and any reduction in width that would cause improper sealing and reduction in pressure rating. Proper fastening should also be checked.
- Threaded Connection – The threads on the threaded connections should be checked for any damage that could potentially compromise the sealing of the threads or the strength of the connection.
- Outlet – The valve’s outlet should be inspected to make sure there is not any corrosion or other debris accumulation within that could inhibit the operation of the valve.
- External Surface – The valve should be checked for any damage that has occurred that could restrict or impair the operation of the valve. Tubing lines, bent piping, and other external attachments are commonly damaged and can cause unfitting function.
- Valve Tag – The tag information should be inspected and verified to the service conditions. Some of the items on the tag that are to be verified are the set pressure, CDTP, and capacity in appropriate unit of measure for the service fluid. If any of the tag information is found to not correspond to the conditions of the system, the valve should be removed and replaced with an appropriate one. A missing tag also warrants further inspections.

If for any reason the valve has failed the visual inspection and the valve is deemed to be dangerous to test, the set pressure inspection and the leak inspection should not be carried out. Immediate replacement or repair of the valve should instead be carried out.

MERCER VALVE CO., INC. RESERVES THE RIGHT TO CHANGE  
PRODUCT DESIGNS AND SPECIFICATIONS WITHOUT NOTICE.



**MERCER VALVE COMPANY, INC.**  
**8500 SERIES DIRECT SPRING OPERATED PRESSURE RELIEF VALVE**  
**INSTALLATION, OPERATION AND MAINTENANCE MANUAL**

***b) Set Pressure Inspection***

During the set pressure inspection, the set pressure is verified in accordance with the ASME BPVC. For all valves set 70psi (500kPa) and above, the set pressure has a tolerance of  $\pm 3\%$  of the set pressure. For all set pressure below 70psi (500kPa) the tolerance is  $\pm 2\text{psi}$  ( $\pm 15\text{kPa}$ ). If the valve has a CDTP associated with it due to temperature and/or backpressure, the test pressure is checked to the CDTP. Even with a CDTP the set pressure tolerance is calculated based on the actual nameplate set pressure. The set pressure test should be performed before and after any repairs.

The set pressure is inspected to the definition listed in NB-18, a publication by the National Board of Pressure Vessel Inspectors, which is found at <http://www.nationalboard.org/>. This publication lists all ASME BPVC certified pressure relief valves. It indicates the correct set pressure definition and other characteristics of a valve. The set pressure has been defined to achieve a particular operational characteristics. If the wrong set pressure definition is used in the inspection test, the valve's set pressure will not be accurate and it may not operate appropriately.

The correct fluid for testing has to be used to achieve accurate results. For gas/vapor service, nitrogen or compressed air is used as the test fluid, while for liquid service, water is used. If the incorrect fluid is used during the testing, the test's results will be inaccurate. Depending on the size of the valve and its set pressure, the set pressure discrepancy can vary outside of ASME tolerances.

Setting procedures should be in accordance with ASME PTC 25. The rate of the system pressure increase should be slow when the pressure is within 15% of the set pressure. Within this range, the rate should never be more than 2psi/sec (15kPa/sec). Ideally each pressure increment on the pressure gauge should be clearly read as the pressure is increased. Slow pressure increase helps to accurately read the pressure gauge.

The procedures for testing set pressure are as follows:

1. Check the set pressure definition from NB-18. For Mercer 8500 Series Valves, a crisp "pop" is the definition of set pressure.
2. Rigidly connect the valve to a test fixture.
3. Slowly increase the pressure on the inlet side until the valve opens. This will be the set pressure of the valve. **If the pressure reaches more than 1.5 times the expected set pressure but the valve hasn't opened, do not proceed with the test. The valve is considered stuck closed and has failed.**
4. Verify the set pressure 2-3 more times. Verifications should be no more than  $\pm 1\%$  or  $\pm 0.5\text{psi}$  ( $\pm 3.5\text{kPa}$ ), whichever is greater, from the average of all verifying pops.

If the test equipment is not adequate, the results can produce false readings. Refer to section 9 on proper test equipment.

MERCER VALVE CO., INC. RESERVES THE RIGHT TO CHANGE  
PRODUCT DESIGNS AND SPECIFICATIONS WITHOUT NOTICE.

**MERCER VALVE COMPANY, INC.**  
**8500 SERIES DIRECT SPRING OPERATED PRESSURE RELIEF VALVE**  
**INSTALLATION, OPERATION AND MAINTENANCE MANUAL**

**Common Set Pressure Definitions**

-POP – A crisp “pop” sound from the valve. The “pop” sound is made from the rapid increase in the lift of the disk allowing flow out of the valve.

-1<sup>st</sup> Audible sound – The 1<sup>st</sup> sound heard from the outlet of the valve. This definition is usually for gas service.

-1<sup>st</sup> Steady Stream – A continuous stream from the outlet of the valve. This stream should flow out from the outlet and not dribble down the outlet. This definition is associated with liquid service PRVs.

***c) Leak Inspection***

After the set pressure is verified, the valve undergoes a leak inspection. This is performed to verify the disk and seat are sealed to a degree appropriate for the type of pressure relief valve being tested. Leak tests are always performed below the set pressure of the valve, usually at a certain percentage of the set pressure. The leak check is usually performed at 90% of the set pressure or 5psi (34.5kPa) below the set pressure, whichever is greater. If the valve has a CDTP, the leak test pressure will be below the CDTP in lieu of the set pressure. Mercer Valve Co. Inc. should be contacted for proper leak pressure and specification for the valve. In the tests, the pressure is held steady for a length of time and any leakage is observed. Before this test is performed, the valve must have had its set pressure examined.

There are several methods used in testing for leakage. All of the tests can indicate a leak at the seat but some of the tests are more sensitive to leakage than others.

One common test for gas valves is listed in API STD 527. In this test, the outlet is blocked with a tube coming out of it into a cup of water. See Figure 4. The tube and water are observed for any bubbles developing in the water from the tube’s end. This test has specific requirements for its apparatus, pressure, and duration of observation. This specification should be reviewed before testing the valve. For soft seated valves, such as the 8500 Series, zero bubbles are observed for one minute to pass leak inspection per API 527.

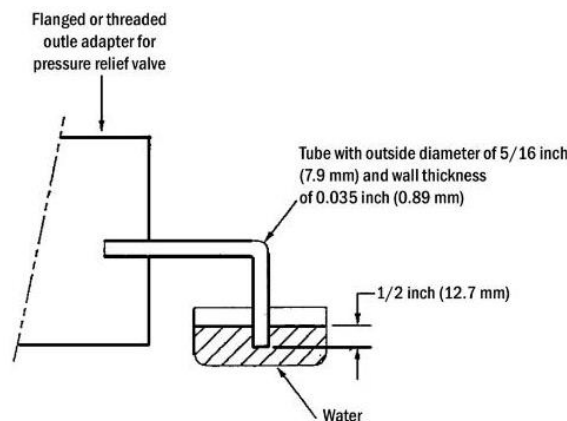

**Figure 4: API 527 Leak Check Apparatus**

MERCER VALVE CO., INC. RESERVES THE RIGHT TO CHANGE  
PRODUCT DESIGNS AND SPECIFICATIONS WITHOUT NOTICE.

**MERCER VALVE COMPANY, INC.**  
**8500 SERIES DIRECT SPRING OPERATED PRESSURE RELIEF VALVE**  
**INSTALLATION, OPERATION AND MAINTENANCE MANUAL**

Flow gauges can also be used to check for leakage. These tests are similar to the API 527 test except a flow gauge is attached instead of a cup of water.

Soap film test is another common method for testing for leaks. In this test the valve's seat and disk are sprayed with a soap and water mixture. The mixture is then observed for any growth of bubbles.

Another simple test is to apply a membrane, a wet paper towel for example, on to the outlet. This membrane seals the outlet. If there is any leakage, the pressure will push the membrane out causing it to bulge.

Sometimes there is not a way to access the outlet due to outlet piping when a valve is left on the unit. In these cases the valve cannot be leak checked by normal means. One method of checking for a seat leak is by maintaining a blocked in pressure in the valve's inlet. In this test, a block valve must be installed below the pressure relief valve and it must be closed during the test. It is important to make sure that the gas used to pressurize the valve does not react with the system fluid in these tests. If the pressure remains stable during the test, there are no leaks present. If the pressure is not stable, there is a potential leak and the valve should be removed for further testing. Even though the test indicates a leak, it doesn't guarantee that it's from the valve. It could be in the connections on the inlet or the block valve. This is why the valve should be removed and rechecked on a test stand if it fails from this method.

**Backpressure Testing**

The purpose of backpressure testing is to check for leaks in the secondary pressure zone (the outlet side of the pressure relief valve). This includes the body, bonnet, outlet flange, and all parts included in the upper valve assembly. Backpressure testing is not required by ASME for field repair. If this is conducted, it should be performed before the valve seal wire has been attached.

The backpressure test is performed after the valve has been assembled and set to the correct set pressure. The test is performed by attaching a sealed and controlled pressure to the outlet and then entirely submerging the valve in a solution of water treated with rust inhibitor. The pressure in the secondary pressure zone is brought to 30psig (200kPa) at a minimum. For PRVs installed on systems with superimposed backpressure, this test should be performed at the backpressure of the system. This is the pressure required by the ASME BOILER AND PRESSURE VESSEL CODE, SECTION VIII, PART UG-136(d) "Production Testing by Manufacturers and Assemblers". The valve is then visually inspected for any leaks by checking for bubbles coming from any part of the valve.

MERCER VALVE CO., INC. RESERVES THE RIGHT TO CHANGE  
PRODUCT DESIGNS AND SPECIFICATIONS WITHOUT NOTICE.

**MERCER VALVE COMPANY, INC.**  
**8500 SERIES DIRECT SPRING OPERATED PRESSURE RELIEF VALVE**  
**INSTALLATION, OPERATION AND MAINTENANCE MANUAL**

## 9. Test Equipment

Testing and inspections can be performed in multiple locations. They are performed onsite in place (in situ testing), onsite on a mobile test unit, or offsite in a shop or test facility. Each environment offers its own advantages and disadvantages.

### **a) In Situ Testing**

Testing and inspecting in place eliminates the laborious task of removing and handling the valve. This is especially desirable with large PRVs. Additionally, not disturbing the existing connections reduces the chance of compromising the existing seals. This type of testing is very useful when a system cannot be shut down for long lengths of time. However there are disadvantages. The inspection process is more difficult because the accessibility of the valve is reduced. The outlet pipe is often still attached and the internal parts are not observable for the visual inspection. This can also make it difficult to leak check. Different methods for leak checking are required. In addition, the set pressure testing process is difficult. Block valves are mandatory to be able to properly test the set pressure. Even with a block valve under the valve, the volume under the valve may not be sufficient to accurately test the set pressure. A heavy warm or simmer can cause false readings as a result of insufficient test volume. Gauge placement is critical to get an accurate pressure reading. If the gauge is placed too far away from the valve or the line has too many restrictions, there will be pressure loss. When this happens the pressure gauge will indicate a pressure that includes the pressure loss. This is an inaccurate reading compared to the actual pressure at the valve's inlet. The supply pressure can also be a factor. Usually the pressure source in these types of tests is far away from actual valve. Compressed air or nitrogen bottles are heavy and usually a line is run from the bottles to the valve. The length of this line can create a pressure drop. This will usually mean that additional pressure in the bottles will be required to properly test the set pressure of the valves. Typical testing apparatus can be seen in Figure 5 and Figure 6.

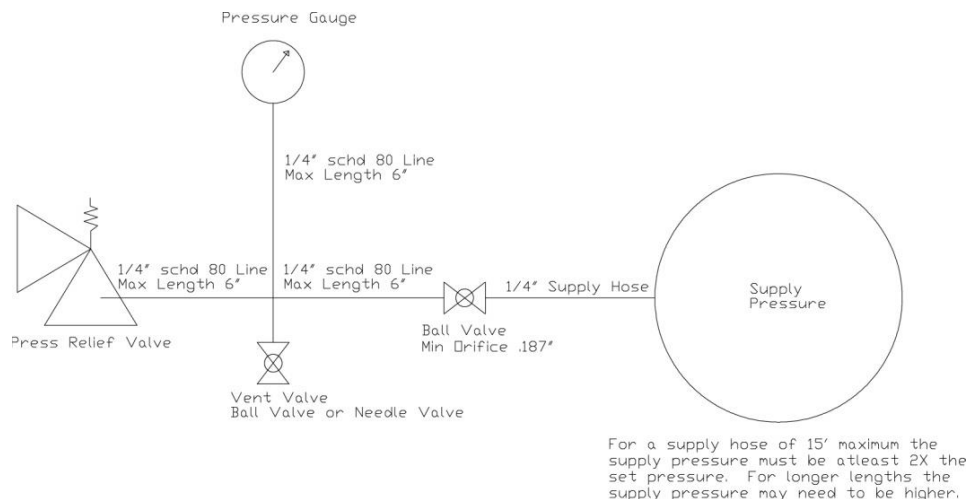

**Figure 5: Diagram of Proper In Situ Testing Apparatus**

MERCER VALVE CO., INC. RESERVES THE RIGHT TO CHANGE  
PRODUCT DESIGNS AND SPECIFICATIONS WITHOUT NOTICE.

**MERCER VALVE COMPANY, INC.**  
**8500 SERIES DIRECT SPRING OPERATED PRESSURE RELIEF VALVE**  
**INSTALLATION, OPERATION AND MAINTENANCE MANUAL**



Figure 6: Picture of Typical In Situ Testing

***b) Offsite Testing***

Offsite testing allows for the most thorough and accurate testing and inspection. The valves are removed from the units and brought to a shop. In the shop a valve can be completely tested and inspected. The shop environment gives the technician the most advantages because more tools are available, there is adequate space to work, and test benches enable accurate results. All of the same concerns in testing are still present in offsite testing as in situ testing. The volume of pressure, valve simmer, pressure losses to the gauges, and supply line pressure are all factors in getting an accurate result. Proper assembly of a test bench is crucial in limiting these effects. The main disadvantage in offsite testing is time. A valve must be removed from the unit and then transported to the shop. After testing, it is transported back to the field to be installed. This time frame can be long and cause delays.

For gas/vapor valves, there should be approximately 1/4ft<sup>3</sup> (7 liters) or more capacity below the valve when setting. This volume is sufficient to test the set pressure for most 4 x 6 M orifices and smaller valves accurately. To see other valve characteristics (e.g. blowdown) a larger vessel is required. If excessive warn is observed during the test, a larger volume is required. See Figure 7 for an example of a test bench.

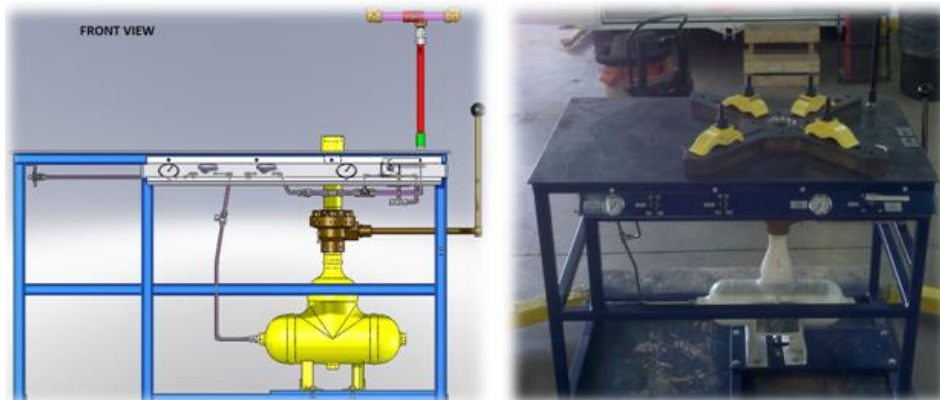

Figure 7: Typical Gas/Vapor Test Stand

MERCER VALVE CO., INC. RESERVES THE RIGHT TO CHANGE  
PRODUCT DESIGNS AND SPECIFICATIONS WITHOUT NOTICE.

**MERCER VALVE COMPANY, INC.**  
**8500 SERIES DIRECT SPRING OPERATED PRESSURE RELIEF VALVE**  
**INSTALLATION, OPERATION AND MAINTENANCE MANUAL**

For liquid testing, the test bench, at a minimum, should have enough volume to perform 5 to 10 consecutive set pressure tests before the test stand has to be refilled with liquid. Approximately 2ft<sup>3</sup> (60 liters) of volume is required for most valves. The larger the volume the more accurate the settings will be. To see other valve characteristics (e.g. blowdown) a larger vessel is required. The test bench must be set up so that liquid is present at the nozzle each time the PRV is opened. This can be accomplished with a J-tube design or a down tube that is completely submerged into the liquid. See Figure 8 to see an example. In both styles, gas pressure is used to push the liquid through the valve's inlet, generating continuous liquid flow absent of any gas.

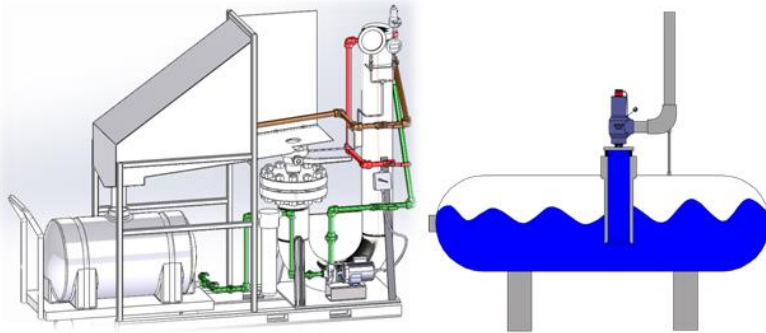

Figure 8: Typical Liquid Test Stand Setups  
(J-Tube left, Down Tube right)

**c) Mobile Test Units**

Mobile testing units are similar to offsite testing. The valve is removed from the application. This enables a thorough inspection. Mobile testing units can save time because transporting the valve isn't done. Mobile test units are often not setup to test all types and sizes. The testing equipment on a mobile test unit can vary in size. Some mobile test units have the similar test stands as an offsite test stand allowing for larger valves to be tested accurately. Other mobile test units are setup only for smaller valves. In each case, the limitations of the test stand should be documented and only used for the sizes and pressure that it is designed for. See Figure 9 for an example.

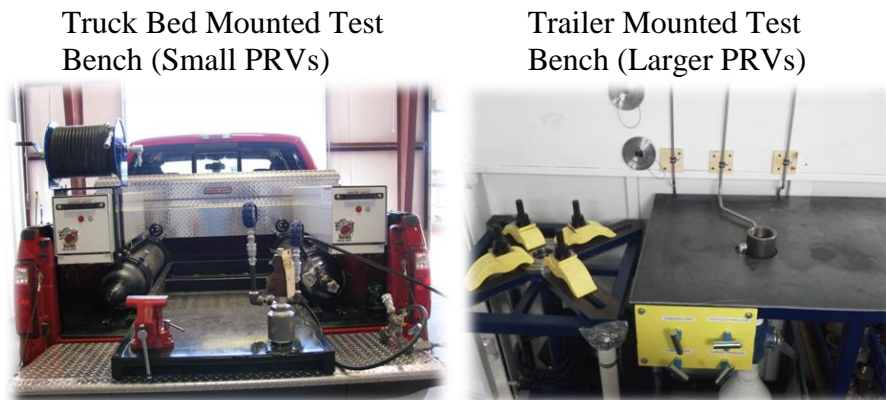

Figure 9: Typical Mobile Test Stand Setups

MERCER VALVE CO., INC. RESERVES THE RIGHT TO CHANGE  
PRODUCT DESIGNS AND SPECIFICATIONS WITHOUT NOTICE.

**MERCER VALVE COMPANY, INC.**  
**8500 SERIES DIRECT SPRING OPERATED PRESSURE RELIEF VALVE**  
**INSTALLATION, OPERATION AND MAINTENANCE MANUAL**

**d) Test Gauges**

When testing the set pressure or leak checking, it is recommended that two pressure gauges are used. This enables quick identification if they are reading incorrectly. If the gauges are not reading identical values within their respective tolerances, it is an indication that at least one gauge is inaccurate and both should be checked to make sure they are calibrated correctly. At least one of the gauges should be an analog (dial) gauge that is not liquid filled. This type of gauge responds to pressure quickly and give accurate readings. Digital gauges can be used for the second gauge if desired. Digital gauges have to be used carefully because quick pressure increases are not always seen on the gauge readings. The test gauges should have at least 0.25% accuracy over their full scale. The portion of the gauge used should be selected so that the tolerance of it is more stringent than the set pressure's tolerance. For analog gauges, only the middle 1/3 or less of the gauge should be used; it is the most accurate portion of the gauge. Each gauge should be calibrated using a dead weight tester. Monthly calibrations of the gauges are recommended.

**e) Lift Checking**

The lift of the PRV is checked by seeing how much the disk subassembly moves from the closed to opened positions. Figure 10 depicts a typical apparatus for checking the lift of a PRV. To use the standard lift check setup, the PRV is placed in an arbor press upside down; the PRV's set spring must initially have tension. A rod is placed through the inlet and touches the disk. The rod should be sized to fit in the inlet base without damaging the seat or touching the side walls of the nozzle insert. The lift is the measurement of the displacement of the disk from the closed position to the mechanical stops at the full open position. The shaft of the arbor press will press against the rod sticking out of the valve inlet base. To find the lift, a slight force is applied by using the arbor press. A dial indicator is placed on the arbor press so that it can measure the displacement of the arbor press shaft. The measurement will be the PRV's lift. The minimum lift for certified PRVs can be found in NB-18 publication, which is located on the National Board website [www.nationalboard.org](http://www.nationalboard.org). If the PRV doesn't meet the minimum lift, there is something wrong and the valve must be reexamined.

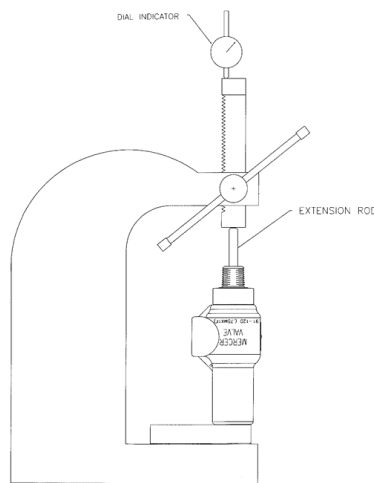

**Figure 10: Lift Checking Apparatus**

MERCER VALVE CO., INC. RESERVES THE RIGHT TO CHANGE  
PRODUCT DESIGNS AND SPECIFICATIONS WITHOUT NOTICE.

**MERCER VALVE COMPANY, INC.**  
**8500 SERIES DIRECT SPRING OPERATED PRESSURE RELIEF VALVE**  
**INSTALLATION, OPERATION AND MAINTENANCE MANUAL**

## **10. Tester Qualifications**

Only qualified individuals should perform PRV tests and repairs. They should be trained to test and calibrate pressure relief valves. They should understand how to properly operate the equipment and know the hazards involved. They should be familiar with the specific PRV being tested and know how it functions and operates. It is recommended that the individual attend factory approved training class for each type of valve worked on.

The end user's company will have additional requirements for the individual conducting the PRV inspection. These requirements should be checked before any PRV work is carried out.

Government authorities can also have requirements for the individual. For every PRV installment, regional specifications that apply should be reviewed.

It is recommended that the individual be qualified in a program similar to US DOT OPS Operator Qualification. This is a qualification program for pipeline operators. Operator Qualification (OQ) Rules can be found in 49 CFR Part 192, Subpart N; and 49 CFR Part 195, Subpart G.

It is also recommended that any company that repairs PRVs is VR certified through ASME and The National Board of Boiler and Boiler Inspectors. VR is an accreditation program administered by the National Board for the repair to pressure relief valves. A PRV repair is any process or operation that affects the flow passage, capacity, function, or pressure-retaining integrity; this includes cleaning. VR companies are certified to work on all types of pressure relief valves.

MERCER VALVE CO., INC. RESERVES THE RIGHT TO CHANGE  
PRODUCT DESIGNS AND SPECIFICATIONS WITHOUT NOTICE.



**MERCER VALVE COMPANY, INC.**  
**8500 SERIES DIRECT SPRING OPERATED PRESSURE RELIEF VALVE**  
**INSTALLATION, OPERATION AND MAINTENANCE MANUAL**

**11. Tool List**

The following Tool List shows the recommended tool to be used with an associated component. The list is not exhaustive and additional tools may be necessary.

**a) Valve**

**Table 1: Tools Used on 8500 Series PRVs**

<b>Tool</b>	<b>Where it is Used</b>
Wire Cutter	Seal Wire
11/16" Open End Wrench	Lock Nut
7/32" Allen Wrench	Adjustment Screw
9/16 Open Wrench	Center Bushing
Adjustable 1-1/8" to 5-5/8" Hex/Straight Jaw Wrench	Inlet Base
1" Open End Wrench	Nozzle/Seat Subassembly (1/2" Orifice)
Special 1" Flat Socket (optional)	Nozzle/Seat Subassembly (1/2" Orifice)
Pick	O-Ring (Removal)
Torque Wrench*	Nozzle/Seat Subassembly (Installation)

*\*Review section 14 for the required value of the torque wrench.*

**b) Miscellaneous**

**Table 2: Miscellaneous Items Used**

Nickel Based Anti-Size (similar to Loctite® LB 771™)
Medium Strength Thread Retainer (similar to Blue Loctite® 242®)
High Strength Thread Retainer (similar to Red Loctite® 271®)
Fine Grade Abrasive Hand Pad (similar to Scotch-Brite™ 7447®)
Phenyl-methyl Silicon Grease (similar to Molykote® 33)
Water Resistant NLGI #2 Grease (similar to Aqua Lube Marine Grease)

MERCER VALVE CO., INC. RESERVES THE RIGHT TO CHANGE  
PRODUCT DESIGNS AND SPECIFICATIONS WITHOUT NOTICE.

**MERCER VALVE COMPANY, INC.**  
**8500 SERIES DIRECT SPRING OPERATED PRESSURE RELIEF VALVE**  
**INSTALLATION, OPERATION AND MAINTENANCE MANUAL**

## **12. Disassembly**

The following general procedure is recommended for the disassembling of a Mercer 8500 Series PRV. Non-standard, “special”, configurations are possible and these instructions may not be reflective of them; a special configuration is indicated by a special code at the end of the PRV’s part number. See section 17. Always make sure there is no pressure in the system prior to removing a PRV.

### **a) Standard**

1. Cut and remove the seal wire and unscrew the cap to expose the adjustment screw. See Figure 3.
  - i) Go to section 12 b) if the valve is a lift lever configuration.
2. Loosen the lock nut from the adjustment screw. See Figure 11.

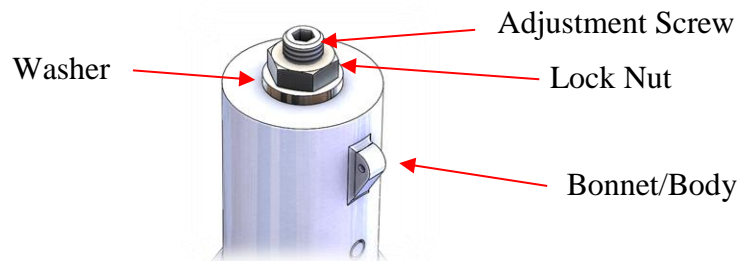

**Figure 11: 1” Body Upper Bonnet Components**

3. Relieve the compression on the spring by turning the adjustment screw counter clockwise. This is important so that components will not spring out and pose a hazard. If the adjustment screw begins to appear as residing back into the bonnet during the relieving of the preload, then the spring compression has been completely removed and the adjustment bushing is beginning to re-compress the spring.
4. Rigidly support the body to prevent movement during disassembly.
5. Unscrew the inlet base using the appropriate wrenching flats. See Figure 1.
6. Remove the set spring and discard the disk subassembly. See Figure 12.
  - i) A replacement disk is included in the repair kit.
7. Remove and discard the inlet base seal. See Figure 12.
  - i) A replacement base seal is included in the repair kit.

MERCER VALVE CO., INC. RESERVES THE RIGHT TO CHANGE  
PRODUCT DESIGNS AND SPECIFICATIONS WITHOUT NOTICE.

**MERCER VALVE COMPANY, INC.**  
**8500 SERIES DIRECT SPRING OPERATED PRESSURE RELIEF VALVE**  
**INSTALLATION, OPERATION AND MAINTENANCE MANUAL**

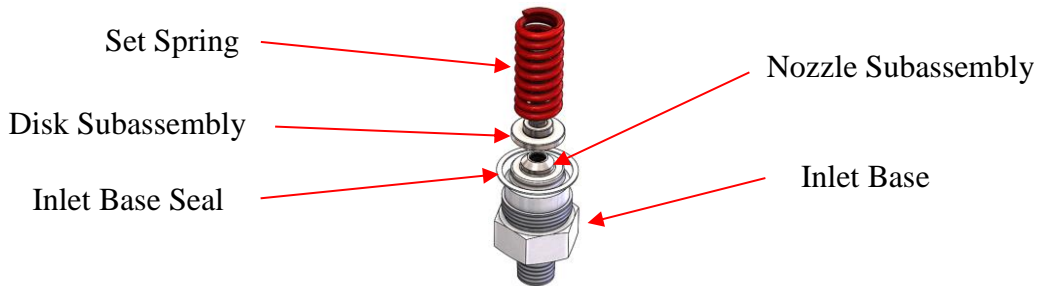

Figure 12: Inlet Base Components

8. Rigidly support the inlet base.
9. Unscrew and discard the nozzle subassembly using the appropriate tool. See Table 1. The nozzle will have thread retainer on its thread.
  - i) A replacement nozzle subassembly is included in the repair kit.
10. Remove and discard the nozzle base o-ring. See Figure 13.
  - i) A replacement o-ring is included in the repair kit.

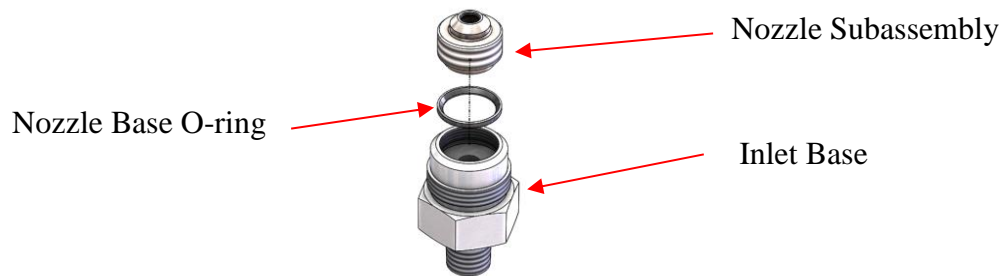

Figure 13: Nozzle/Seat Subassembly

11. Remove the lock nut and washer. See Figure 14.
  - a) If the valve is a lift lever and the center bushing is being removed, the lift lever lock nut is unscrewed as well.

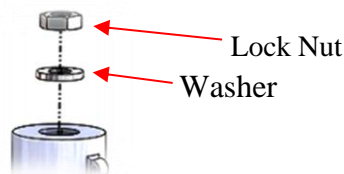

Figure 14: 1" Body Upper Bonnet Components

12. Push downwards on the adjustment screw and center bushing to remove them from the bonnet.
13. Disassemble the center bushing from the adjustment screw if they are still together. See Figure 15.
14. Remove and discard the o-ring located on the center bushing.
  - a) Older models have two o-rings located on the center bushing.

MERCER VALVE CO., INC. RESERVES THE RIGHT TO CHANGE  
PRODUCT DESIGNS AND SPECIFICATIONS WITHOUT NOTICE.

**MERCER VALVE COMPANY, INC.**  
**8500 SERIES DIRECT SPRING OPERATED PRESSURE RELIEF VALVE**  
**INSTALLATION, OPERATION AND MAINTENANCE MANUAL**

- i) Two replacement o-rings are included in the repair kit.
15. Remove and discard the o-ring located on the adjustment screw. See Figure 15.
- i) A replacement o-ring is included in the repair kit.

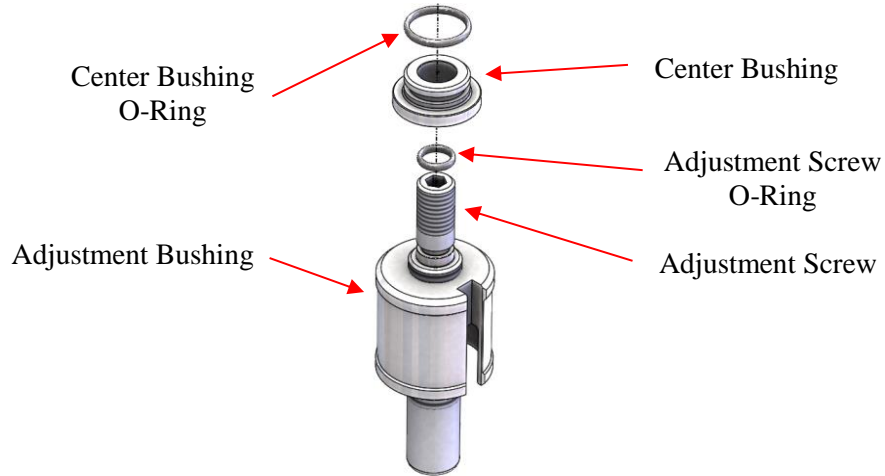

Figure 15: 1" Body Inner Bonnet Components

16. Unscrew the adjustment bushing from the adjustment screw. The adjustment bushing has left handed threads. See Figure 15.
17. The PRV is disassembled.

***b) Lift Levers***

1. Cut and remove the seal wire. See Figure 16.

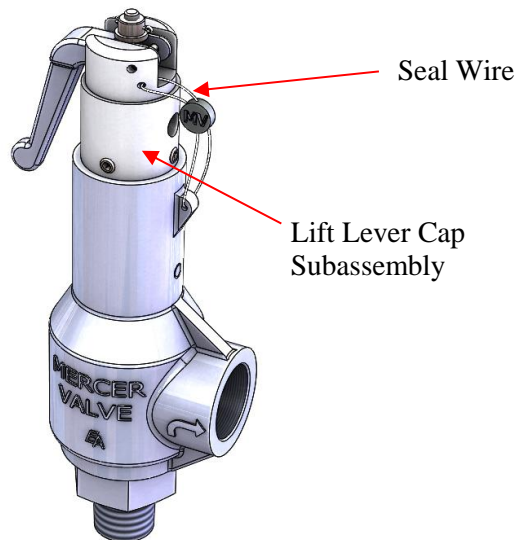

Figure 16: 8500 Series with a Lift Lever

MERCER VALVE CO., INC. RESERVES THE RIGHT TO CHANGE  
PRODUCT DESIGNS AND SPECIFICATIONS WITHOUT NOTICE.

**MERCER VALVE COMPANY, INC.**  
**8500 SERIES DIRECT SPRING OPERATED PRESSURE RELIEF VALVE**  
**INSTALLATION, OPERATION AND MAINTENANCE MANUAL**

2. Bend straight and pull out the cotter pin. See Figure 17. Set it aside.
  - i) A replacement cotter pin is not provided in the repair kit.
3. Unscrew and remove the stem lift nut. See Figure 17.

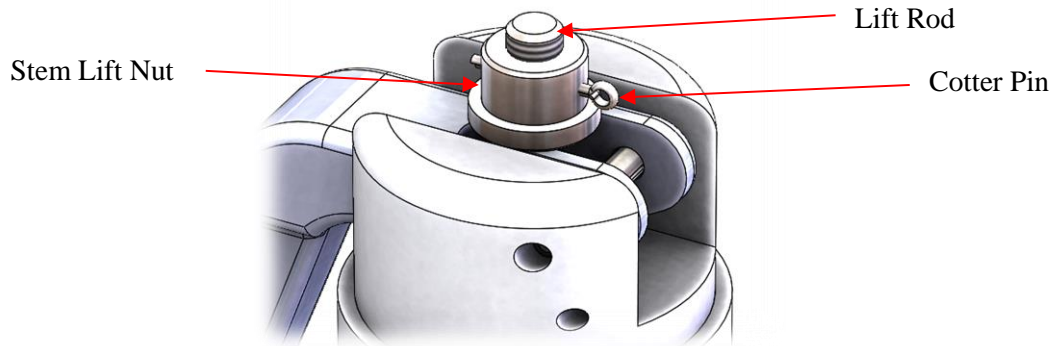

Figure 17: Upper Portion of Lift Lever Cap

4. Loosen the three lift lever cap set screws. See Figure 18. These must be unscrewed enough so that they no longer engage the lift lever lock nut.

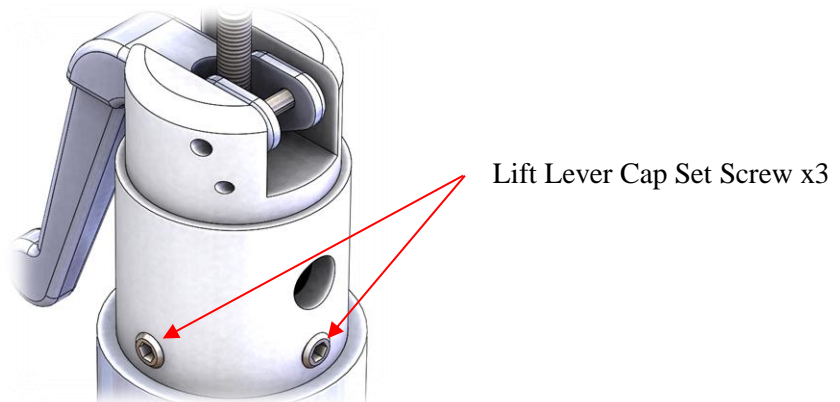

Figure 18: Lift Lever Cap Set Screws

5. Raise the entire lift lever cap to remove it from the bonnet.
6. Unscrew and remove the seal adjustment nut. See Figure 19.
  - a) If the valve has a closed lift lever configuration, there will be an o-ring under this nut. Remove and discard this o-ring.
    - i) A replacement o-ring is included in the repair kit.
  - b) If the valve has an open lift lever configuration, there won't be an o-ring.

MERCER VALVE CO., INC. RESERVES THE RIGHT TO CHANGE  
PRODUCT DESIGNS AND SPECIFICATIONS WITHOUT NOTICE.

**MERCER VALVE COMPANY, INC.**  
**8500 SERIES DIRECT SPRING OPERATED PRESSURE RELIEF VALVE**  
**INSTALLATION, OPERATION AND MAINTENANCE MANUAL**

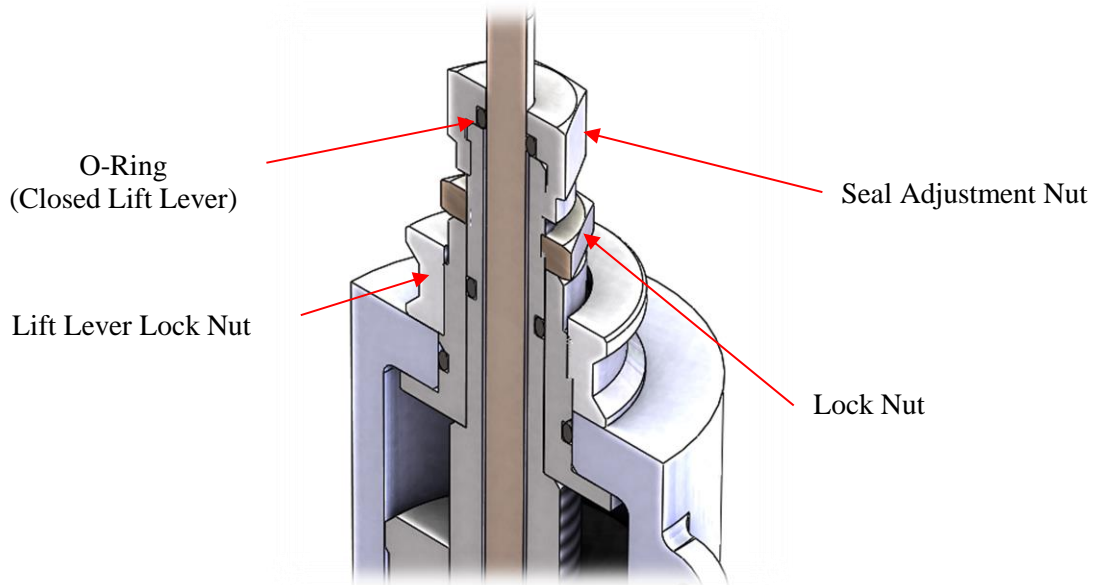

Figure 19: Removed Lift Lever Cap

7. Loosen the lock nut by using two additional jam nuts on the adjustment screw to prevent it from turning. See Figure 20.
  - i) The additional jam nuts are not included in the repair kit.

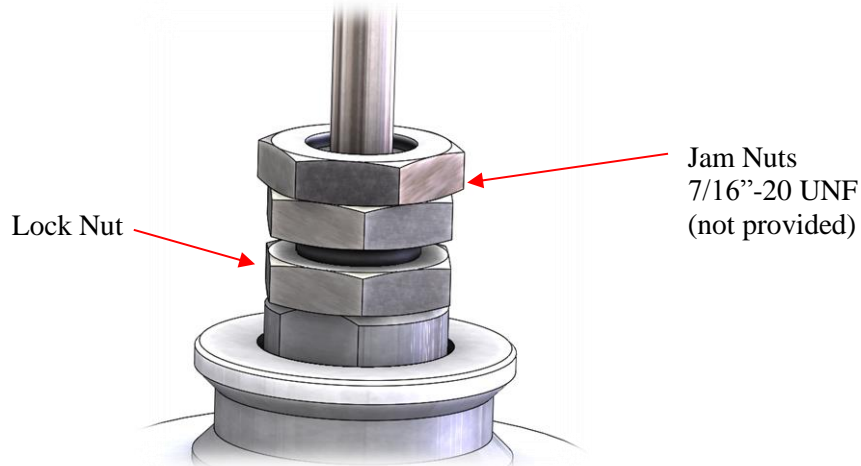

Figure 20: Jam Nuts Used on Adjustment Screw

8. Turn the adjustment screw counter clockwise to remove the spring load. Use the jam nuts to apply torque to the adjustment screw.
9. Remove the jam nuts.

*If removing the center bushing, continue with the following, otherwise skip to step 11.*

MERCER VALVE CO., INC. RESERVES THE RIGHT TO CHANGE  
PRODUCT DESIGNS AND SPECIFICATIONS WITHOUT NOTICE.

**MERCER VALVE COMPANY, INC.**  
**8500 SERIES DIRECT SPRING OPERATED PRESSURE RELIEF VALVE**  
**INSTALLATION, OPERATION AND MAINTENANCE MANUAL**

10. If necessary\*, the lift lever lock nut may be removed by using a wrench on the flats of the center bushing and a pipe wrench on the lift lever lock nut. One wrench remains stationary while the other is turned to loosen the two parts.
- a) \*These components do not have to be disassembled unless the center bushing o-ring is suspected of leaking. Removing this part is not recommended.
  - b) This lock nut has high strength thread retainer applied and can be difficult to remove.

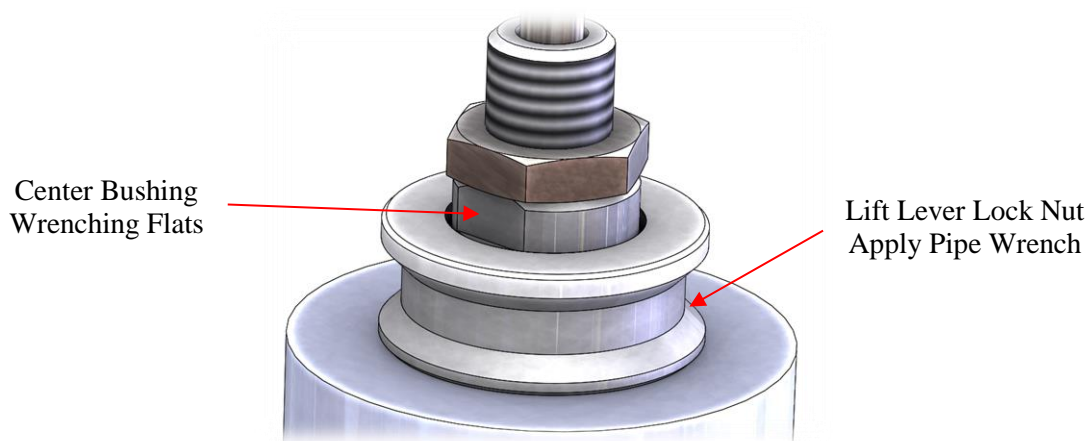

**Figure 21: Lift Lever Lock Nut Removal**

11. The disassembly is now typical of the process described for non-lift lever configurations. Return to step 4 in the aforementioned instructions.

MERCER VALVE CO., INC. RESERVES THE RIGHT TO CHANGE  
PRODUCT DESIGNS AND SPECIFICATIONS WITHOUT NOTICE.

**MERCER VALVE COMPANY, INC.**  
**8500 SERIES DIRECT SPRING OPERATED PRESSURE RELIEF VALVE**  
**INSTALLATION, OPERATION AND MAINTENANCE MANUAL**

### 13. Component Inspection

The following general procedure is recommended for the inspection of an 8500 Series PRV. New parts should be inspected.

1. Inspect the seat for cuts and abrasions. The seat is the non-metallic element in the nozzle subassembly.
  - a) If there are only minor scratches or abrasions, the seat may be polished and restored.
  - b) Polish the seat area lightly with a fine grade abrasive pad. Be careful not to damage the soft seat.
  - c) If the seat is damaged with deep abrasions and cuts, it should be replaced.
2. Referring to Figure 22, measure the diameter  $D_s$  of the nozzle. This diameter must be in the range of values listed in Table 3.

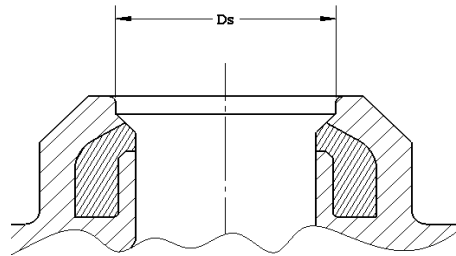

Figure 22: Critical Seat Dimension

Table 3: Critical Seat Dimension Values

ORIFICE SIZE	NOZZLE DIAMETER $D_s$ , in (mm)	
	MINIMUM	MAXIMUM
$\frac{1}{2}$ "	0.620 (15.75)	0.622 (15.80)

3. Inspect the disk subassembly. Especially examine the spherical surface portion that engages the seat; this surface must be clean and smooth.
  - a) This surface may be polished with a fine grade abrasive to restore the disk if only minor imperfections exist. Any form of heavier cutting **must not** be done.
  - b) If the spherical surface is damaged or scratched, the disk needs to be replaced.
4. Referring to Figure 23, measure the diameter  $D_d$ . This diameter must be within the range of values listed in Table 4.

MERCER VALVE CO., INC. RESERVES THE RIGHT TO CHANGE  
 PRODUCT DESIGNS AND SPECIFICATIONS WITHOUT NOTICE.



**MERCER VALVE COMPANY, INC.**  
**8500 SERIES DIRECT SPRING OPERATED PRESSURE RELIEF VALVE**  
**INSTALLATION, OPERATION AND MAINTENANCE MANUAL**

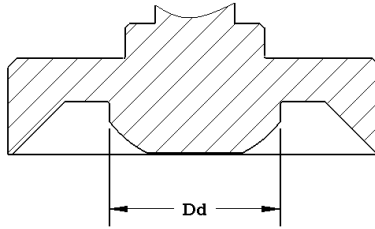

Figure 23: Critical Disk Dimension

Table 4: Critical Disk Dimension Values

ORIFICE SIZE	DISK DIAMETER Dd	
	MINIMUM in (mm)	MAXIMUM in (mm)
1/2"	0.614 (15.60)	0.616 (15.65)

5. Check the portion of the disk stem that slides inside the adjustment screw bore. Verify that its surface is smooth. The surface must not have severe wear. See Figure 24 for an example.

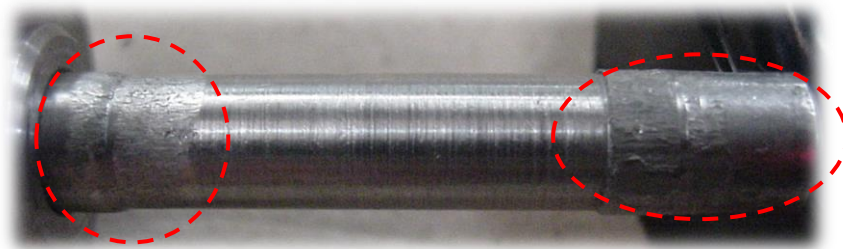

Figure 24: Example of Severe Wear on a Disk Stem

6. Inspect the set spring for damage. Clean or replace the spring if necessary. Check that the spring appears square. A spring with too much curvature can cause the valve to leak.
7. Verify that the correct spring is being used for the intended service and set pressure. This is checked by measuring the wire diameter and the inside diameter of the spring. Cross reference these values to the spring chart. This is a separate document.
8. Swab out the internal bore of the adjustment screw to insure that it is clean and free from obstructions such as dirt or grease. Also examine that severe wear within this part does not exist.

MERCER VALVE CO., INC. RESERVES THE RIGHT TO CHANGE  
 PRODUCT DESIGNS AND SPECIFICATIONS WITHOUT NOTICE.

**MERCER VALVE COMPANY, INC.**  
**8500 SERIES DIRECT SPRING OPERATED PRESSURE RELIEF VALVE**  
**INSTALLATION, OPERATION AND MAINTENANCE MANUAL**

## 14. Reassembly

The following procedure is recommended for the reassembling of a Mercer 8500 Series PRV. Parts should not be difficult to put back together and excessive force should be used.

### **a) Cleaning & Lubrication**

#### ***Cleaning:***

- All of the valve's parts **except** the o-rings and nozzle subassemblies may be cleaned using a solvent bath. **Remove all soft goods before applying solvent.**
- An abrasive pad may be used to clean dirty surfaces. Always rinse off parts after using Scotch-Brite™.
- All parts shall be dried and drained before reassembly.
- **Parts should never be media blasted.** This process leaves beads/sand in the valve which can cause improper function. It may also ruin a required surface finish condition.
- After parts have been cleaned, they may be re-lubricated.

#### ***Lubricating:***

- All o-rings should be lubricated with silicone grease similar to Molykote® 33 grease.
- The adjustment screw threads should be lubricated with a small amount of anti-seize, preferably a nickel base type.
- The adjustment bushing should be greased on the outer cylindrical area with a water resistant lubricant similar to Aqualube.
- **Never apply grease, oil, or other lubricants on seats, seal faces, or sliding components.**

### **b) Valve Reassembly**

1. Lightly apply a small amount of anti-seize to the threads of the adjustment screw. See Figure 26.
2. Thread the adjustment bushing onto the adjustment screw. This has left handed threads. Screw the adjustment bushing down onto the adjustment screw until approximately 2 threads of the adjustment screw are visible from the top. See Figure 15.
3. Lightly lubricate the outer surface of the adjustment bushing. See Figure 25.

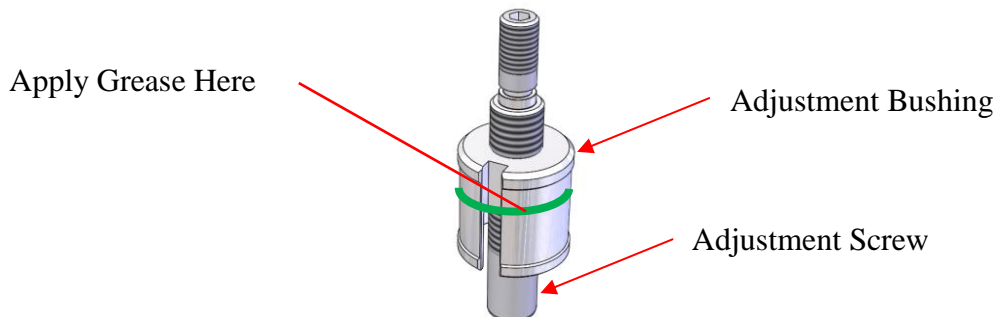

**Figure 25: Adjustment Screw and Adjustment Bushing**

MERCER VALVE CO., INC. RESERVES THE RIGHT TO CHANGE  
PRODUCT DESIGNS AND SPECIFICATIONS WITHOUT NOTICE.

**MERCER VALVE COMPANY, INC.**  
**8500 SERIES DIRECT SPRING OPERATED PRESSURE RELIEF VALVE**  
**INSTALLATION, OPERATION AND MAINTENANCE MANUAL**

4. Lightly lubricate the adjustment screw o-ring.
5. Carefully place the adjustment screw o-ring onto the adjustment screw making sure not to cut the o-ring. The o-ring should reside in a notch groove below the upper threads of the adjustment screw. See Figure 26.

*If the valve has a lift lever, go to section 14 c).*

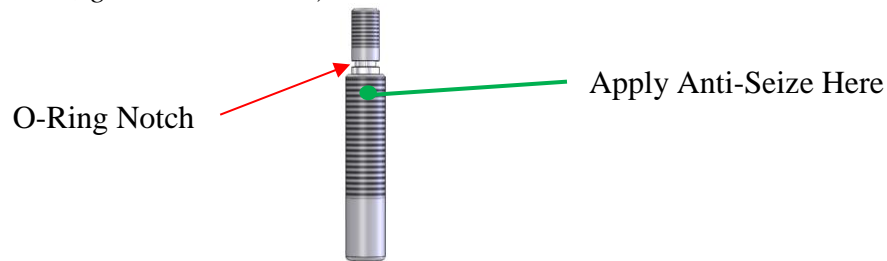

Figure 26: Adjustment Screw O-Ring Notch

6. Lightly lubricate the center bushing o-ring.
  - a) Older 8500 series may have two o-rings and two notches on the center bushing.
7. Carefully place the center bushing o-ring onto the center bushing. The o-ring should reside in a notch on the center bushing. See Figure 27.



Figure 27: Center Bushing O-Ring Notch

8. Install the center bushing over the top of the adjustment screw. See Figure 15 for the proper orientation.
9. Carefully slip fit the adjustment screw and adjustment bushing fully into the bore of the bonnet by aligning the index pin of the body with the notch of the adjustment bushing.
  - a) The adjustment bushing must slip into the valve bore freely but with little radial play.
  - b) Remove and inspect/re-clean parts if the fit is not correct.
  - c) **DO NOT FORCE THE ADJUSTMENT BUSHING INTO THE VALVE BODY.** Forcing the parts may restrict valve lift and **cause serious malfunction.**
10. Place the washer over the top of the bonnet and onto the adjustment screw with the rounded edge side of the washer away from the body (towards the top of the valve). See Figure 11.
11. Thread on the lock nut over the top of the bonnet and onto the adjustment screw.
  - a) **DO NOT** fully tighten. The lock nut just needs to be finger tight at this point only to retain the inner bonnet components.
  - b) The lock nut will be tightened once the setting process is completed.
12. Lightly lubricate the nozzle base o-ring.
13. Install the nozzle base o-ring into the lower corner of the nozzle pocket. See Figure 28.

MERCER VALVE CO., INC. RESERVES THE RIGHT TO CHANGE  
PRODUCT DESIGNS AND SPECIFICATIONS WITHOUT NOTICE.

**MERCER VALVE COMPANY, INC.**  
**8500 SERIES DIRECT SPRING OPERATED PRESSURE RELIEF VALVE**  
**INSTALLATION, OPERATION AND MAINTENANCE MANUAL**

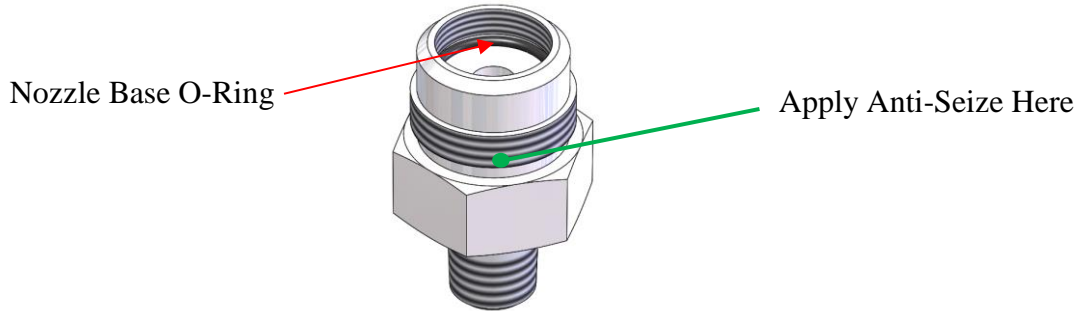

Figure 28: Inlet Base

14. Put a dot of medium strength thread retainer onto the threads of the nozzle. See Figure 29.



Figure 29: Thread Retainer Location on Nozzle

15. Thread the nozzle subassembly into the nozzle base.  
 a) Do not put any lubricant on the seat.  
 16. Rigidly hold the inlet base.  
 17. Tighten the nozzle to the appropriate value as shown in Table 5.

Table 5: Nozzle Torque Values

Nozzle Orifice	Torque, lbf-ft (N-m) ± 5%
1/2"	100 (136)
1/2" orifice 316 SS <small>(see section 17)</small>	No Torque – use channel lock pliers to snug down

18. Hold the valve body upside down.  
 19. Before reinstalling the spring, insert the disk subassembly's stem into the bore of the adjustment screw and simulate the valve opening operation. The disk stem must slide freely within the bore of the adjustment screw.  
 20. Remove the disk subassembly.  
 21. Check and make sure the set spring slides over the disk freely without sticking.  
 22. Install the spring over the adjustment screw so it is resting on the lower portion of the adjustment bushing.  
 23. Install the disk subassembly into the adjustment screw and spring.  
 a) Do not put any lubricant the disk or disk stem.

MERCER VALVE CO., INC. RESERVES THE RIGHT TO CHANGE  
 PRODUCT DESIGNS AND SPECIFICATIONS WITHOUT NOTICE.

**MERCER VALVE COMPANY, INC.**  
**8500 SERIES DIRECT SPRING OPERATED PRESSURE RELIEF VALVE**  
**INSTALLATION, OPERATION AND MAINTENANCE MANUAL**

24. Place the base seal onto the inlet base. See Figure 12.
25. Put a small amount of anti-seize on the threads of the inlet base that get screwed into body. See Figure 28.
26. While still holding the body of the valve upside down, finger tighten the inlet base subassembly threads into the body while making sure all internal parts remain aligned. Also make sure that the inlet base seal is centered on the inlet base and body and is not getting bent or caught on the inlet threads.
27. Tighten the inlet base to the appropriate value as shown in Table 6.

**Table 6: Inlet Base Torque Values**

<b>Body Size (Thread Size)</b>	<b>Torque, lbf-ft (N-m) ± 5%</b>
1" (1½"-12)	350 (475)

28. Turn the valve upright.
29. If any pipe plugs/fittings were removed, wrap their threads with 3 wraps of PTFE pipe fitting tape, reinstall them, and then tighten them approximately 2 to 3 turns past finger tight.
30. Turn the adjustment screw clockwise until resistance is felt; the spring is engaged. Turn the adjustment screw an additional 4-5 more times. This is increasing the compression on the spring.
  - a) If the PRV has a lift lever option, utilize two jam nuts to turn the adjustment screw. See Figure 20. The jam nuts are tighten against each other to 100 lbf-ft (136 N-m).
31. Check the lift of the valve. Refer to section 9 Test Equipment e) Lift Checking. The measured lift of the PRV should meet or exceed the minimum lift denoted in NB-18 publication. If valve does not meet lift, disassemble and inspect parts.
32. Adjust the set pressure of the valve. See section 15 Valve Setting Procedure.
33. Tighten the lock nut to the appropriate value listed in Table 7. Tighten by utilizing two wrenches, one on the lock nut and the other on the adjustment screw (or jam nuts). The wrench on the adjustment screw (or jam nut) should be held stationary during tightening so that the adjustment screw does not turn and alter the spring compression.
  - a) If the PRV has a lift lever and jam nuts were used to turn the adjustment screw, the jam nuts will be removed once set pressure adjustment is finalized.

**Table 7: Lock Nut Torque Values**

<b>Orifice Sizes</b>	<b>Torque, lbf-ft (N-m) ± 5%</b>
½" Lock Nut	25 (34)
Lift Lever Lock Nut	80 (108)

34. Re-check the set pressure to verify set pressure is still as intended.
35. Conduct a leak check. See section "**8 Inspections; c) Leak Inspection.**"
36. Install cap and seal with lock wire. See Figure 3.
  - a) If the PRV has a lift lever option use the following instructions listed in 14 c) step 8.
37. Reassembly is complete.

MERCER VALVE CO., INC. RESERVES THE RIGHT TO CHANGE  
 PRODUCT DESIGNS AND SPECIFICATIONS WITHOUT NOTICE.

**MERCER VALVE COMPANY, INC.**  
**8500 SERIES DIRECT SPRING OPERATED PRESSURE RELIEF VALVE**  
**INSTALLATION, OPERATION AND MAINTENANCE MANUAL**

**c) Lift Lever**

*If the center bushing was removed begin with step 1, otherwise skip to step 4.*

1. Lightly lubricate the center bushing o-ring.
2. Carefully place the center bushing o-ring onto the center bushing making sure not to cut the o-ring. The o-ring should reside in a notch on the center bushing. See Figure 30.

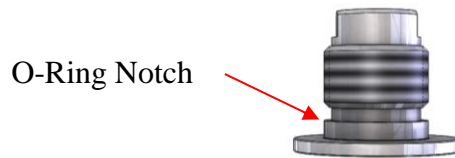

Figure 30: Center Bushing O-Ring Notch

3. Install the center bushing over the top of the adjustment screw. See Figure 31.

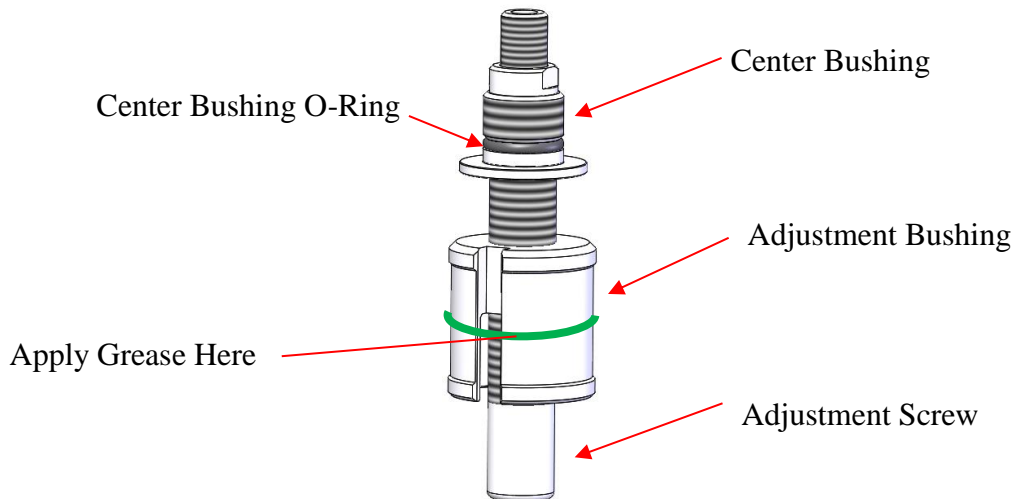

Figure 31: Inner Bonnet Components  
(Shown with center bushing)

4. Carefully slip fit the adjustment screw and other parts into the bore of the body.
  - a. The adjustment bushing must slip into the valve bore freely.
  - b. Remove and inspect/re-clean parts if the fit is not correct.
  - c. **DO NOT FORCE THE ADJUSTMENT BUSHING INTO THE VALVE BODY.** Forcing the parts may restrict valve lift and **cause serious malfunction.**

*If the center bushing was removed continue with step 5, otherwise skip to step 7.*

5. Apply a small amount of high strength thread retainer on the threads of the center bushing only. See Figure 32.

MERCER VALVE CO., INC. RESERVES THE RIGHT TO CHANGE  
PRODUCT DESIGNS AND SPECIFICATIONS WITHOUT NOTICE.

**MERCER VALVE COMPANY, INC.**  
**8500 SERIES DIRECT SPRING OPERATED PRESSURE RELIEF VALVE**  
**INSTALLATION, OPERATION AND MAINTENANCE MANUAL**

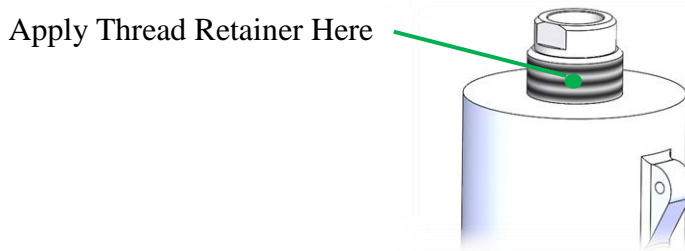

**Figure 32: Thread Retainer on Center Bushing**

6. Tighten the lift lever lock nut against the center bushing. When tightening, use the flats on the center bushing to stop the center bushing from turning. Tighten to the appropriate value shown in Table 7.
7. Thread the lock nut onto the adjustment screw finger tight against the center bushing. Do not tighten fully.

*Continue with assembling the bottom portion of the PRV in section 14 b) step 12.*

***To install a lift lever cap, the PRV must have its set pressure adjusted first. Remove any jam nuts used.***

8. Remove the two jam nuts.
9. Lubricate and place the seal adjustment nut o-ring over the lift lever rod. See Figure 33. If the valve has an open lift lever configuration, this step is omitted since there will not be an o-ring used.

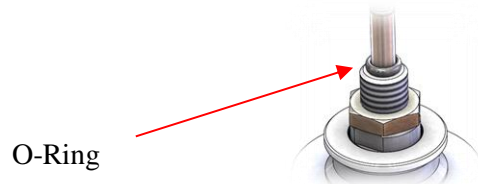

**Figure 33: Lift Lever O-ring**

10. Slip the seal adjustment nut over the lift rod and thread it onto the adjustment screw. The seal adjustment nut should be finger tightened so that the adjustment screw does not get turned.
11. Place the lift lever cap subassembly over the adjustment screw and lift lever lock nut with the orientation shown in Figure 34.
12. Insert and tighten the three lift lever cap set screws to the value listed in Table 8. See Figure 18.

MERCER VALVE CO., INC. RESERVES THE RIGHT TO CHANGE  
PRODUCT DESIGNS AND SPECIFICATIONS WITHOUT NOTICE.

**MERCER VALVE COMPANY, INC.**  
**8500 SERIES DIRECT SPRING OPERATED PRESSURE RELIEF VALVE**  
**INSTALLATION, OPERATION AND MAINTENANCE MANUAL**

**Table 8: Lift Lever Cap Set Screw Torque**

	<b>Torque, lbf-ft (N-m) ± 5%</b>
1/4"-20 Lift Lever Cap Set Screw	6.3 (8.6)

13. Thread the stem lift nut on the lift rod until its pin hole is aligned with the lift rod's pin hole. It will be in light contact with the lift lever. Once installed the lift lever should have some play in its action.
14. Insert the cotter pin through the two pin holes.
15. Slightly bend the end of the cotter pin so that it is captured within the lift rod and stem lift nut assembly.
16. Attach the seal wire through the small unused hole of the lift lever cap as shown in Figure 34.

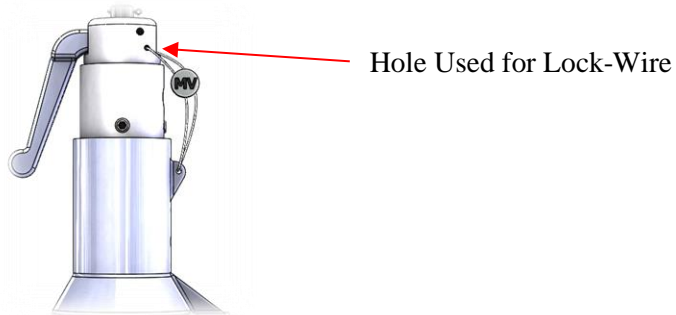

**Figure 34: Lift Lever Orientation and Lock Wire**

17. Reassembly is complete.

MERCER VALVE CO., INC. RESERVES THE RIGHT TO CHANGE  
PRODUCT DESIGNS AND SPECIFICATIONS WITHOUT NOTICE.



**MERCER VALVE COMPANY, INC.**  
**8500 SERIES DIRECT SPRING OPERATED PRESSURE RELIEF VALVE**  
**INSTALLATION, OPERATION AND MAINTENANCE MANUAL**

## **15. Valve Setting Procedure**

### ***a) Cold Differential Test Pressure (CDTP)***

High temperature cause materials to relax and results in a set pressure change. Additionally, because the 8500 series PRV is a conventional design, superimposed backpressure affects its set pressure. The Cold Differential Test Pressure (CDTP) is a compensation made to the set pressure for temperature and backpressure when the PRV is not in service. The CDTP is the pressure that the valve will open at when it's not exposed to the backpressure and temperature conditions, i.e. when the valve is being set on a test stand. The PRV will open at its set pressure in the service conditions. Variable superimposed backpressure cannot be accounted for with a CDTP.

The CDTP will be listed on the PRV's nameplate for the original set pressure conditions. If the valve's service has changed, the CDTP might need to be recalculated. For more information on calculating CDTP, contact Mercer Valve. When examining and calibrating the set pressure on a test bench, the CDTP is used. If the CDTP line on the nameplate is blank, there is not a CDTP for that PRV and it should be calibrated to its set pressure.

### ***b) Setting the Valve***

Setting procedures should be in accordance with ASME PTC 25. The rate of the system pressure increase should slow when close to set pressure (within 15% to 20% of the set pressure). Within this range the rate should never be more than 2psi (15kPa)/sec. Ideally each pressure increment on the pressure gauge is clearly read as it changes. Slow pressure increase help to accurately read the pressure readings.

1. Rigidly connect the valve to a test fixture.
2. For Mercer 8500 Series PRVs, a crisp "pop" is the definition of set pressure for gas/vapor valves.
3. Increase the spring tension by turning the adjustment screw in the clockwise direction.
4. Slowly increase the pressure on the inlet side until it reaches the bench test pressure. If the valve pops before the bench test pressure is reached, increase the spring tension and again increase the pressure to the bench test pressure.
5. Slowly reduce the spring tension by turning the adjustment screw counter clockwise while keeping the system pressure at the bench test pressure. Turn until the valve "pops".
6. Verify the bench test pressure 3-4 more times making any adjustments as needed. Verifying each "pop" should be no more than  $\pm 1\%$  or  $\pm 0.5\text{psi}$  (3.5kPa), whichever is greater, of the average of all the verifying pops.
7. While holding the adjustment screw still, tighten the locknut to the appropriate value listed in Table 7.
8. Re-verify the setting after the locknut has been tightened. Make any adjustments needed.  
**Install the cap and seal wire after leak check and backpressure checking.**

MERCER VALVE CO., INC. RESERVES THE RIGHT TO CHANGE  
PRODUCT DESIGNS AND SPECIFICATIONS WITHOUT NOTICE.

**MERCER VALVE COMPANY, INC.**  
**8500 SERIES DIRECT SPRING OPERATED PRESSURE RELIEF VALVE**  
**INSTALLATION, OPERATION AND MAINTENANCE MANUAL**

**16. Tag Information**

Information and identification about the valve can be found on the tag, also called the nameplate. This information can be used to verify if the valve is installed in the proper service. It also can be used to get an appropriate replacement. A PRV's original nameplate must always remain attached. If changes are made that would alter its information, such as the part number, the original information should be crossed out but left legible. The updated information should either be stamped on the original or on an attached repair nameplate. The information on the tag is as follows:

- Product Number (PN) – This indicates the series and identifies the configuration of the valve.
- Serial Number (Serial No.) – This will be a unique identifier to the valve and provides a means of traceability through Mercer Valve Co. Inc.
- Set Pressure (Set P.) – Identifies the set pressure of the valve while in its service conditions.
- Cold Differential Test Pressure (CDTP) – This indicates the bench test pressure that was used to compensate for temperature and/or backpressure of the service conditions.
- Backpressure (Back Press.) – This indicates possible pressure in the valve's outlet.
- Valve Capacity (CAP. Air/Water) – This indicates the capacity of the valve at standard atmospheric conditions of air for gas service valves or water for liquid valves.
- Service Temperature (Service Temp.) – This indicates the valve's normal operating condition. It is not a temperature limit.
- Size – This indicates the nominal inlet size of the valve.
- Repair Kit (Repair Kit No.) – This designates the associated repair kit for the product number.
- Date – This indicates the month and year the valve was made.



	<b>MERCER VALVE CO., INC.</b>		
	PATENT # 4,799,506      OKC, OK.		
PN 91-55H11V78U1			
SIZE	1-1/2	IN	SET P. 100 PSI
DATE	5/16		CDTP PSI
CAP. AIR	1617	SCFM	BACK PRESS PSI
CAP. WATER	GPM		SERVICE TEMP 70 F
REPAIR KIT NO.	3H1V1U1		SERIAL NO. XXXXXX
CRN 0G8841.5C			

Figure 35: Example Tag

MERCER VALVE CO., INC. RESERVES THE RIGHT TO CHANGE PRODUCT DESIGNS AND SPECIFICATIONS WITHOUT NOTICE.

**MERCER VALVE COMPANY, INC.**  
**8500 SERIES DIRECT SPRING OPERATED PRESSURE RELIEF VALVE**  
**INSTALLATION, OPERATION AND MAINTENANCE MANUAL**

## 17. Product Number System

*Not all code combinations are valid product numbers. Not all possible configurations are shown. Consult Mercer Valve Co., Inc. for any questions on valid product number configurations.*

### a) Valve Product Numbering

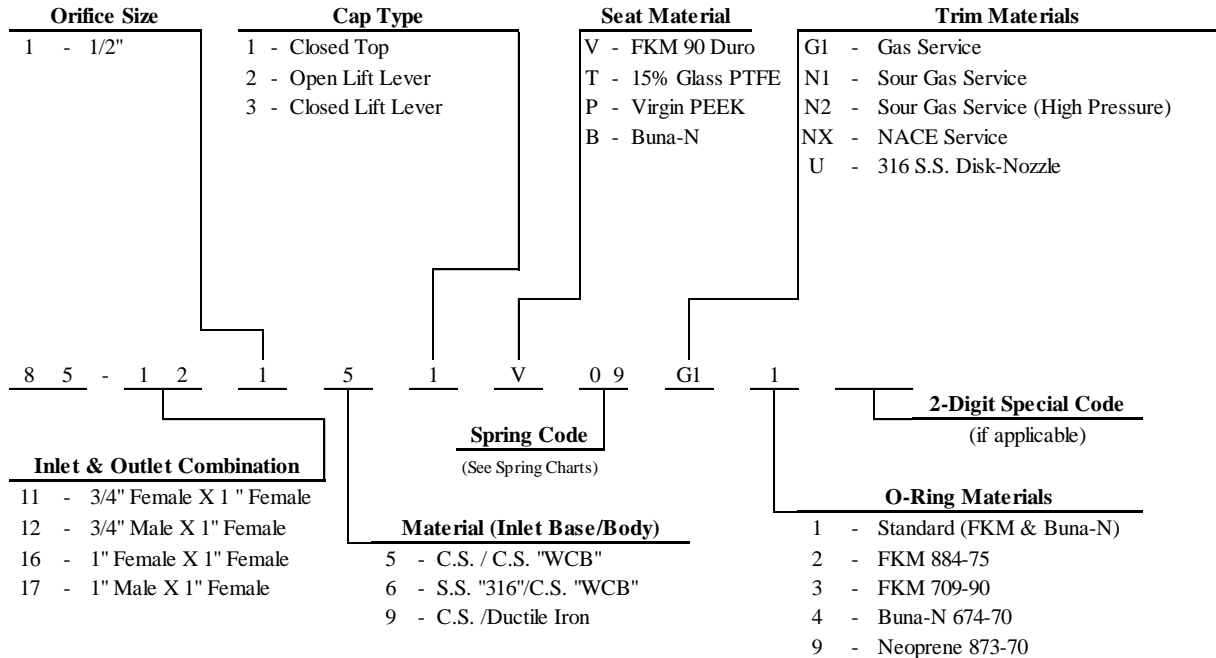

MERCER VALVE CO., INC. RESERVES THE RIGHT TO CHANGE  
 PRODUCT DESIGNS AND SPECIFICATIONS WITHOUT NOTICE.



MERCER VALVE COMPANY, INC.  
8500 SERIES DIRECT SPRING OPERATED PRESSURE RELIEF VALVE  
INSTALLATION, OPERATION AND MAINTENANCE MANUAL

## 18. Exploded Views

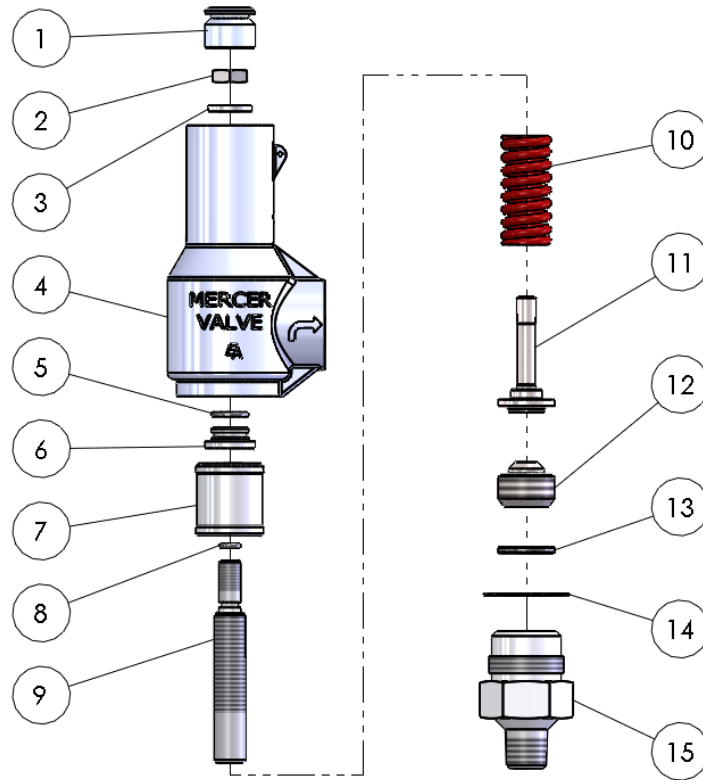

Figure 36: Exploded View of 1" Body

See section Table 9 for part identification.

MERCER VALVE CO., INC. RESERVES THE RIGHT TO CHANGE  
PRODUCT DESIGNS AND SPECIFICATIONS WITHOUT NOTICE.

**MERCER VALVE COMPANY, INC.**  
**8500 SERIES DIRECT SPRING OPERATED PRESSURE RELIEF VALVE**  
**INSTALLATION, OPERATION AND MAINTENANCE MANUAL**

**19. Cutaway View**

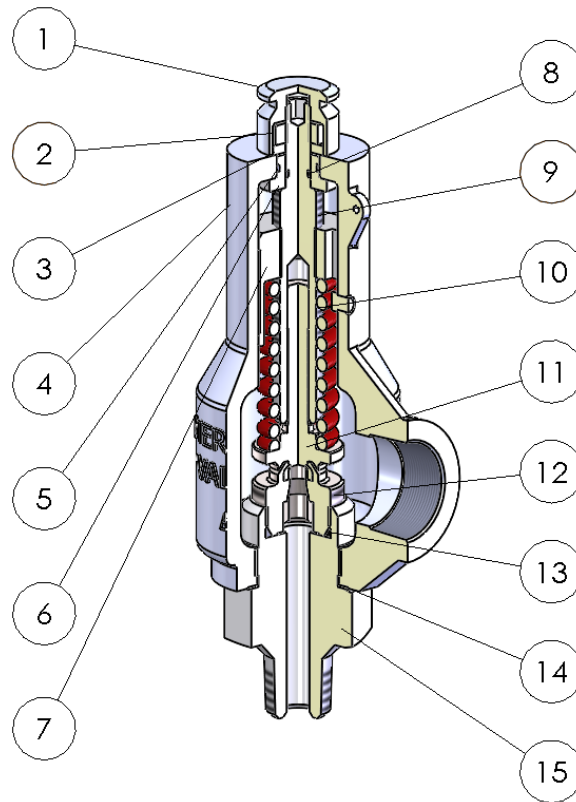

Figure 37: Cutaway View

Table 9: Part Identification

ITEM NO	PART NAME	ITEM NO	PART NAME
1	CAP	9	ADJUSTMENT SCREW
2	LOCKNUT	10	SET SPRING
3	WASHER	11	DISK SUBASSEMBLY
4	BONNET/BODY	12	NOZZLE/SEAT SUBASSEMBLY
5	CENTER BUSHING O-RING	13	NOZZLE BASE O-RING
6	CENTER BUSHING	14	INLET BASE SEAL
7	ADJUSTMENT BUSHING	15	INLET BASE
8	ADJUSTMENT SCREW O-RING		

MERCER VALVE CO., INC. RESERVES THE RIGHT TO CHANGE  
 PRODUCT DESIGNS AND SPECIFICATIONS WITHOUT NOTICE.

**MERCER VALVE COMPANY, INC.**  
**8500 SERIES DIRECT SPRING OPERATED PRESSURE RELIEF VALVE**  
**INSTALLATION, OPERATION AND MAINTENANCE MANUAL**

## **20. Trouble Shooting Guide**

The following describes some but not all problems that could occur in PRVs. This list is not exhaustive and complicated problems and causes may exist which require more involved solutions.

- Always take the proper safety precautions when working with PRVs.
- Always work on the valve within a controlled environment, not on an active pressurized system.

*1) Symptom*

*a) Possible Cause (ordered by priority)*

*i) Solution (ordered by priority)*

**1) There is a leak coming from the valve.**

- a) The disk is not initially fully seated against the nozzle.
  - i) Check for debris between the seat and disk.
- b) The soft seat or disk is damaged.
  - i) Inspect the disk and seat for any signs of abrasions or damages. Repair or replace if necessary.
  - ii) Check media-material chemical compatibility.
- c) The nozzle base o-ring is leaking.
  - i) Disassemble and inspect the nozzle/seat subassembly. Replace if necessary.
- d) Valve is beginning to open (warning) because the operating pressure is approaching the set pressure.
  - i) Check the operating conditions.

**2) The valve is relieving at a pressure lower than the set pressure tolerance allows.  
(Tolerance: -2psi/15kPa or -3% of set pressure, whichever is greater).**

- a) The valve's settings are not correct.
  - i) Re-check the set pressure and adjust accordingly.
- b) The valve's seat is leaking.
  - i) Inspect the disk and seat for damages. Replace or repair as necessary.
- c) Pressure pulses/spikes are causing the valve to open.
  - i) Check and make sure the operating conditions are suitable for the valve.
- d) Vibrations are causing the valve to relieve.
  - i) Check and make sure the operating conditions are suitable for the valve.

**3) The valve is relieving at a pressure higher than the set pressure tolerance allows.  
(Tolerance: +2psi/15kPa or +3% of set pressure, whichever is greater).**

- a) The valve's settings are not correct.
  - i) Re-check the set pressure and adjust accordingly.
- b) The disk's movement is being impeded.

MERCER VALVE CO., INC. RESERVES THE RIGHT TO CHANGE  
PRODUCT DESIGNS AND SPECIFICATIONS WITHOUT NOTICE.

**MERCER VALVE COMPANY, INC.**  
**8500 SERIES DIRECT SPRING OPERATED PRESSURE RELIEF VALVE**  
**INSTALLATION, OPERATION AND MAINTENANCE MANUAL**

- i) Inspect the inside of the valve, the set spring, and the bore of the adjustment screw for build up or damages.
  - c) Superimposed backpressure is causing the valve to remain closed.
    - i) Check and make sure the operating conditions are suitable for the valve.
- 4) The valve is remaining open after it relieves and won't return to the operating pressure.**
- a) Check and make sure the operating conditions are suitable for the valve. The recommend target maximum operating pressure is 15% below set pressure for gas service.
  - b) The disk's movement is being impeded.
    - i) Inspect the inside of the valve, the set spring, and the bore of the adjustment screw for debris build-up or damages.
  - c) The disk or seat is damaged and is allowing large amounts of leakage.
    - i) Inspect the disk and seat for damages. Replace or repair as necessary.
- 5) Valve is chattering.**
- a) Restrictions in either the inlet piping, outlet piping, or a combination of both are causing a pressure drop or build up.
    - i) Check and make sure that there are no restrictions within the inlet piping that would cause a pressure loss greater than 3% of the set pressure.
    - ii) Check and make sure that there are no restrictions within the outlet piping that would cause a pressure build up greater than the allowable over pressure of the valve.
- 6) Set pressure has too much variation.**
- a) Valve's components are dimensionally out of tolerance
    - i) Check the critical dimensions.
    - ii) Check the spring to make sure it is correct for the set pressure and orifice.
  - b) Test equipment is providing false pressure readings.
    - i) Make sure the pressure gauges are calibrated.
    - ii) Verify that the test equipment is producing correct results. Consult NB23, Part 4, section 3.2.5.

MERCER VALVE CO., INC. RESERVES THE RIGHT TO CHANGE  
PRODUCT DESIGNS AND SPECIFICATIONS WITHOUT NOTICE.



**MERCER VALVE COMPANY, INC.  
8500 SERIES DIRECT SPRING OPERATED PRESSURE RELIEF VALVE  
INSTALLATION, OPERATION AND MAINTENANCE MANUAL**

**This page was intentionally left blank.**

MERCER VALVE CO., INC. RESERVES THE RIGHT TO CHANGE  
PRODUCT DESIGNS AND SPECIFICATIONS WITHOUT NOTICE.

Rev.: D  
Date: 31-May-2018  
ECN: 2957

**MERCER VALVE COMPANY, INC.  
8500 SERIES DIRECT SPRING OPERATED PRESSURE RELIEF VALVE  
INSTALLATION, OPERATION AND MAINTENANCE MANUAL**



**MERCER VALVE CO., INC.®**  
"AUTO SEAT TECHNOLOGY"®

**CORPORATE HEADQUARTERS**

9609 NW 4<sup>th</sup> STREET  
OKLAHOMA CITY, OK 73127  
1-800-833-6402  
PHONE: (405) 495-6533, FAX: (405) 495-8728  
[SALES@MERCERVALVE.NET](mailto:SALES@MERCERVALVE.NET)

FOR MORE INFORMATION PLEASE VISIT OUR WEBSITE AT

**[WWW.MERCERVALVE.NET](http://WWW.MERCERVALVE.NET)**

Other company names and product names used in this document are registered trademarks or tradenames of their respective owners.

MERCER VALVE CO., INC. RESERVES THE RIGHT TO CHANGE  
PRODUCT DESIGNS AND SPECIFICATIONS WITHOUT NOTICE.

Rev.: D  
Date: 31-May-2018  
ECN: 2957