

8100 & 9100 SERIES REPAIR KIT

½" DIAM, C, D, & E ORIFICES

A trained professional must perform all valve repairs. For instructions on the procedure for repairing and testing the pressure relief valve, refer to latest revision of the Installation, Operation, and Maintenance Manual for the 8100, 9100 Series or 9100 Series Model 20 (ENG-496000, ENG-502000, and ENG-869000 respectively). These manuals will go through the step-by-step process of disassembly, replacing the parts, assembling the valve, and testing it. All of these repair kits will include a new Nozzle Subassembly (Item 12), Disk Subassembly (Item 11), Base Seal (Item 14), and the valve o-rings (Items 5, 8, & 13). The 9100 Model 20 and valves in 2" bodies will not have item 5 in the kit. Valves in 2" bodies will have an additional o-ring that will be used with the nozzle conversion adapter (Not Shown in Valve Cutaway). Model 20 Valves will have a new bonnet seal in addition to the other parts listed (Not Shown in Valve Cutaway). Use the diagram below to identify which o-rings belong where within the valve.

SPECIFICATIONS

Orifice Size:	½" DIAM	C	D	E
Orifice Diameter, in (mm):	0.520 (13.21)	0.281 (7.14)	0.394 (10.01)	0.520 (13.21)
Orifice Area, in ² (mm ²):	0.212 (136.8)	0.062 (40.0)	0.122 (78.7)	0.212 (136.8)
**Max. Pressure, psig (kPag):	1650 (11376)	8700 (59984)	7500 (51711)	3000 (20684)
ASME Gas Flow Coefficient:	0.798*		0.818	
ASME Liquid Flow Coefficient:	0.639*		0.707	
*=Value calculated from ASME Slope or Flow Factor				
** = Pressure Range only indicates the range of the orifice size, not the parts within the kit.				

ITEM NO	PART NAME	ITEM NO	PART NAME
1	CAP	9	ADJUSTMENT SCREW
2	LOCKNUT	10	SET SPRING
3	WASHER	11	DISK SUBASSEMBLY
4	BONNET/BODY	12	NOZZLE/SEAT SUBASSEMBLY
5	CENTER BUSHING O-RING	13	NOZZLE BASE O-RING
6	CENTER BUSHING	14	INLET BASE SEAL
7	ADJUSTMENT BUSHING	15	INLET BASE
8	ADJUSTMENT SCREW O-RING		

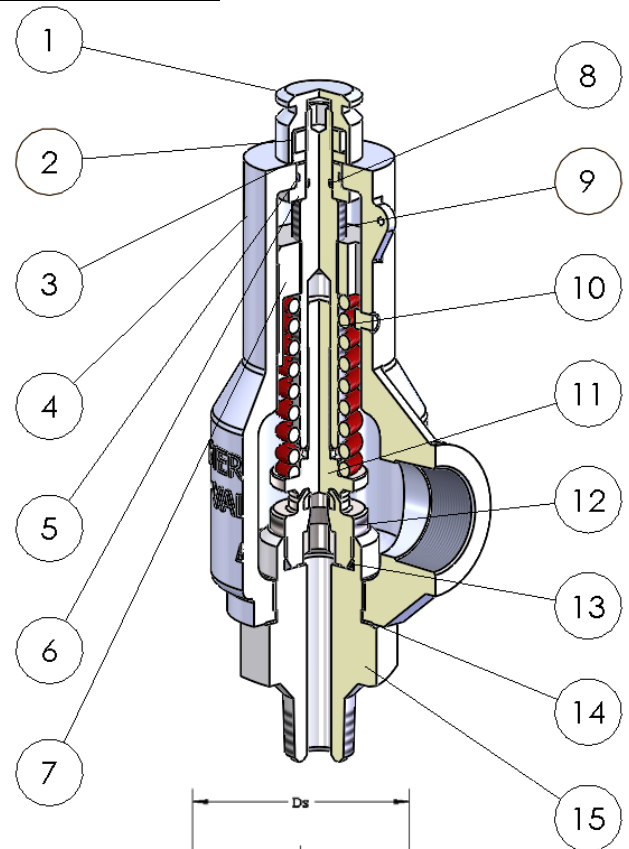
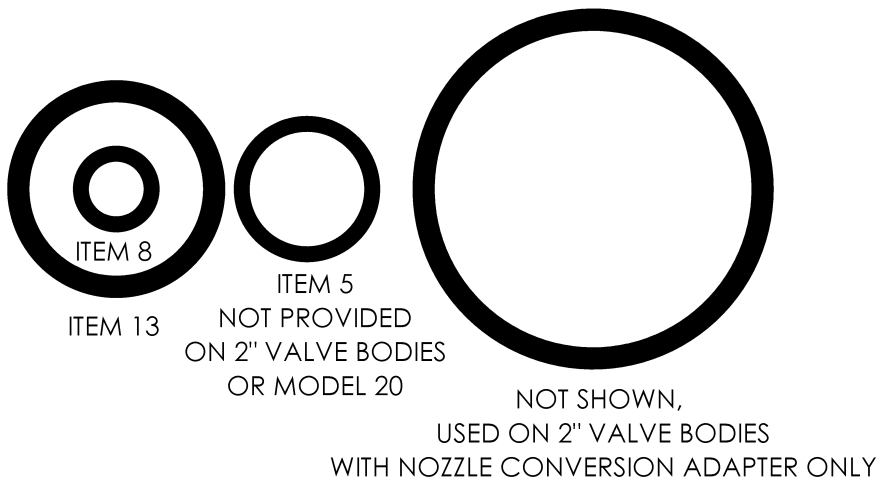

CRITICAL DIMENSIONS

ORIFICE SIZE	NOZZLE DIAMETER D _s , in (mm)		DISK DIAMETER D _d , in (mm)	
	MINIMUM	MAXIMUM	MINIMUM	MAXIMUM
½" DIAM	0.620 (15.75)	0.622 (15.80)	0.611 (15.52)	0.614 (15.60)
C	0.335 (8.51)	0.337 (8.56)	0.329 (8.36)	0.331 (8.41)
D	0.480 (12.19)	0.482 (12.24)	0.472 (11.99)	0.475 (12.07)
E	0.620 (15.75)	0.622 (15.80)	0.611 (15.52)	0.614 (15.60)

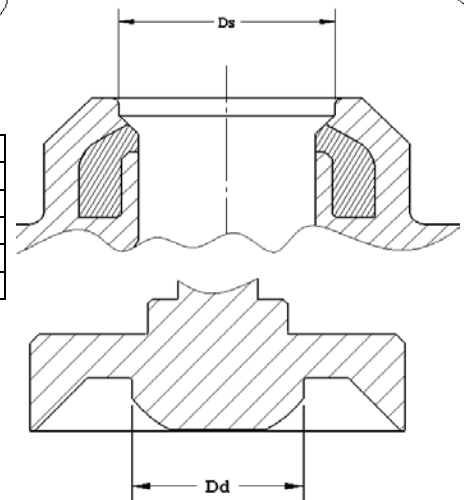



MERCER VALVE CO. INC.

8100 & 9100 SERIES PRESSURE RELIEF VALVE INSTALLATION AND OPERATION INSTRUCTIONS

INSTALLATION - A pressure relief valve should always be installed in a vertical position with its outlet pointing in a horizontal direction on a tank or piping system. When screwing the valve onto the system, always use a square jaw wrench on the designed wrenching flats located at the inlet of the valve, never on the valve's body or bonnet.

One of the most common causes of early failure of a relief valves is seat leakage caused by dirt/debris trapped on the valve seat. Welding slag and piping PTFE tape are among the more common items that cause difficulty. It is recommended that all piping and tank systems be cleaned prior to installation of the relief valve.

A relief valve mounted on a tank should be connected with the minimum length of piping between the tank and the valve. Further, all piping used must be equal or larger than the inlet pipe diameter size of the relief valve, **never smaller**. Any restriction of the inlet to a relief valve may cause unusual valve chatter or relief capacities below the design rating of the valve, which could result in **serious damage**. Similarly, outlet piping from the relief valve should be less than four (4) feet (1.2 m) in length and never of a pipe size diameter smaller than the outlet size of the relief valve. Long runs of small diameter pipe on the outlet of a relief valve will create a serious hazard to life and property. Larger piping is recommended to reduce the built-up back pressure.

Extreme caution is required in the outlet piping if installed outdoors where liquids, if present, could form an ice block in the outlet piping or in the valve's body. In below freezing weather, this will block/restrict flow. Discharge lines must be "weather capped" and provided with a drain hole to prevent any liquid collection in the relief valve body or outlet piping to prevent this.

Safety pressure relief valves must be braced and supported for reaction forces, vibrations, and other external forces applied to the valve in operation. Additionally, important installation factors are contained in paragraph UG-135 and Appendix M of Section VIII of the ASME Boiler and Pressure Vessel Code. If any of these precautions are not taken, serious damage and injury will result.

OPERATION - The valve's set pressure must not exceed the maximum working pressure of the vessel/system. Best performance is usually obtained by installing a valve on a system where the operating pressure is at least **15% less** than the valve's set pressure. A **greater margin is desirable**.

It is also important to check that back pressure and temperature limitations of the process are consistent with valve's ratings. Built-up back pressure should not exceed the allowable overpressure for spring operated valves. Note that each seat and o-ring material has temperature/pressure limitations. Using these materials outside their limitations will cause the valve to fail. Contact Mercer Valve to find different material limitations.

Additionally, corrosion effects from the system's media need to be accounted for in the material selections/compatibilities of the valve's components. Proper material selection and designation is the responsibility of the user/purchaser of the valve. Extra care in material selection must be taken in applications that affect the materials of the valve like Hydrogen service. Standard materials are not acceptable in these types of applications. Contact Mercer Valve Engineering for potential alternative materials.

Carefully check the maximum process fluid input capacities to insure that the valve's relieving capacity is **greater than** the process's capability. It is important that the intended service (gas/liquid) of the valve is installed on a system with same service.

MAINTENANCE & INSPECTION - Mercer Valve Co. recommends all of its pressure relief valves to be **tested annually** for set point and function. During these intervals, a visual inspection, set pressure test, and leak check should be done on the valve. All Mercer Safety Relief Valves are leak checked to at least 90% of set pressure. All inspections and repairs should be done by an authorized and trained professional who has a VR certification.

DO NOT BREAK THE SEAL WIRE. To do so invalidates the manufacturer's warranty to repair or replace the valve. Should resetting be required in a field emergency situation, it should be performed by qualified personnel with calibrated instrumentation. Note that Section VIII of the ASME Boiler and Pressure Vessel Code specifies that valves should only be reset within the installed spring's set pressure range, which is specified by the manufacturer. Consult factory for additional resetting information.

WARRANTY - Mercer Valve warrants the goods delivered hereunder to be free from defects in material and workmanship, under normal use and service, for a period of one (1) year after date of shipment. Mercer's obligation under this warranty is limited to repair or replacement, at Mercer's sole option, of any defective item. Mercer's liability under this warranty is conditioned upon Purchaser giving Mercer immediate written notice of any such defect. Mercer shall have the option of requiring the return of the defective item, transportation prepaid, to establish the claim. Any repair or replacement of defective goods or parts will occur at Mercer's plant in Oklahoma City, Oklahoma. Purchaser shall bear all freight costs incurred in transporting defective goods or parts to and from Mercer's plant. Mercer shall not be held liable for damages caused by delays in repair or replacement of any defective items. The provisions in the Mercer literature and specifications are descriptive only, unless expressly stated as warranties. EXCEPT FOR THE FOREGOING, MERCER EXPRESSLY DISCLAIMS ALL WARRANTIES, EXPRESS AND IMPLIED INCLUDING, WITHOUT LIMITATION, THE IMPLIED WARRANTIES OF MERCHANTABILITY AND FITNESS FOR A PARTICULAR PURPOSE. Mercer's liability to the Purchaser, arising out of the supplying of said goods or their use, whether based upon warranty, contract, or negligence, shall not in any case exceed the cost of correcting defects in, or replacing, the equipment as herein provided. Upon the expiration of said one (1) year, all such liability shall terminate. Mercer shall not in any event be held liable for any special, indirect, or consequential damages. SUITABILITY OF THE MATERIAL AND PRODUCT FOR THE USE CONTEMPLATED BY THE BUYER IS THE SOLE RESPONSIBILITY OF THE BUYER.

Consult the Installation, Operation, and Maintenance Manual for additional information.

MERCER VALVE CO., INC.
9609 NW 4TH STREET, OKLAHOMA CITY, OK 73127
PHONE: (405) 495-6533 • FAX: (405) 495-8728 • 1-800-833-6402
www.mercervalve.net

THINK...MERCER FIRST™